

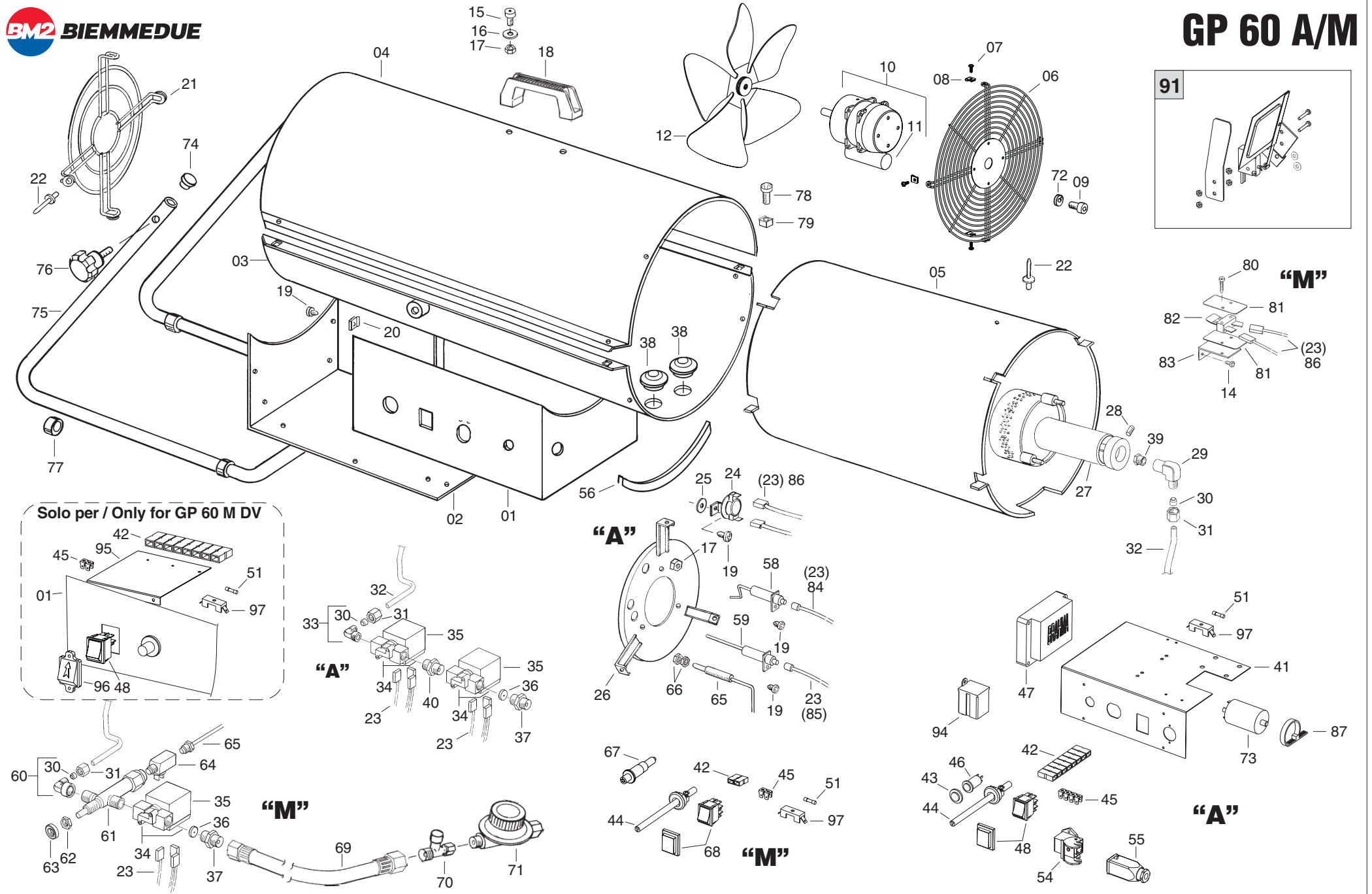

# GP 60 A/M



Da matr. N. - De matr. No. - Von Masch. Nr. - From number:						GP 60M GP 60A	42401001 44701001		
Pos.	Cod.	€	GP 60M	GP 60A	GP 60M DV	LEGENDA	LEGENDE	NOMENKLATUR	PART LIST
1	G03099-7035 G03100-7035 G03091-7035		•	•	•	Basamento	Base	Kastenträger	Base
2	G03047		•	•	•	Coperchio quadro elettrico	Couvercle coffret électrique	Inspectiondeckel	Inspection door
3	G03048		•	•	•	Scocca inferiore	Carrosserie inferieur	Karosserie unterteil	Lower body
4	G03049		•	•	•	Scocca superiore	Carrosserie superieur	Haube	Upper body
5	G03050		•	•	•	Camera di combustione	Chambre de combustion	Brennkammer	Combustion chamber
6	P30147		•	•	•	Griglia aspirazione	Grille aspiration	Ansauggitter	Inlet grill
7	M10505		•	•	•	Vite TC 8x1/2"	Vis TC 8x1/2"	Schraube TC 8x1/2"	Screw TC8x1/2"
8	M20412		•	•	•	Piastrina doppia U42-182	Plaque elastique U42-182	Klemmutter U42-182	Elastic plate U42-182
9	M10317		•	•	•	Vite TCEI M4x8	Vis TCEI M4x8	Schraube TCEI M4x8	Screw TCEI M4x8
10	E10596 E10667		•	•	•	Motore 110 W 230V-50Hz Motore 110 W 110/230V-50Hz	Moteur 110 W 230V-50Hz Moteur 110 W 110/230V-50Hz	Motor 110 W 230V-50 Hz Motor 110 W 110/230V-50 Hz	Motor 110 W 230V-50Hz Motor 110 W 110/230V-50Hz
11	E11204		•	•	•	Condensatore 4 µF	Condensateur 4 µF	Kondensator 4 µF	Condenser 4 µF
12	T10207		•	•	•	Ventola Ø 300 18°	Ventilateur Ø 300 18°	Ventilator Ø 300 218°	Fan Ø 300 18°
14	M10501		•	•	•	Vite TC 4x3/8"	Vis TC 4x3/8"	Schraube TC 4x3/8"	Screw TC 4x3/8"
15	M10316		•	•	•	Vite TCEI M6 x 14	Vis TCEI M6 x 14	Schraube TCEI M6 x 14	Screw TCEI M6 x 14
16	M20106		•	•	•	Rondella Ø 6	Rondelle Ø 6	Abstandsring Ø 6	Washer Ø 6
17	M10704		•	•	•	Dado M6	Ecrou M6	Mutter M6	Nut M6
18	C10202		•	•	•	Maniglia plastica	Poignée	Handgriff	Handle
19	M10508		•	•	•	Vite TC 8x3/8"	Vis TC 8x3/8"	Schraube TC 8x3/8"	Screw TC 8x3/8"
20	M20402		•	•	•	Piastrina doppia U42-032A	Plaque elastique U42-032A	Klemmutter U42-032A	Elastic plate U42-032A
21	P30125		•	•	•	Griglia anteriore inox	Grille avant inox	Ausblagitter	Stainless outlet grill
22	M20603		•	•	•	Rivetto Al 4,9x9	Rivet Al 4,9x9	Niet Al 4,9x9	Rivet Al 4,9x9
23	E00141 E00301		•	•	•	Cablaggio	Cablage	Kabel	Cable
24	E50102		•	•	•	Capsula termostatica Limit	Thermostat bilame Limit	Thermostat Limit	Limit Thermostat
25	M20107		•	•	•	Rondella Ø 5	Rondelle Ø 5	Abstandsring Ø 5	Washer Ø 5
26	G03051		•	•	•	Flangia bruciatore	Bride brûleur	Brenner Teller	Burner plate
27	G01888		•	•	•	Testa di combustione	Brûleur	Brenner	Burner
28	M10603		•	•	•	Grano M5 x 8	Vis M5 x 8	Schraube M5 x 8	Screw M5 x 8
29	I30609		•	•	•	Curva portaugello	Raccord pour gicleur	Düse Ekanschluss	Nozzle connection
30	I30809		•	•	•	Bicono Ø 6	Bicône Ø 6	Doppelkegelring Ø 6	Bicone Ø 6
31	I30808		•	•	•	Dado per bicono Ø 6	Ecrou pour bicône Ø 6	Mutter für Doppelkeg. Ø 6	Nut for bicone Ø 6
32	I40484		•	•	•	Tubo rame sagomato Ø 6	Tuyau cuivre Ø 6	Gaszuführrohr Ø 6	Gas supply pipe Ø 6
33	I30860		•	•	•	Raccordo bicono 90° 1/4" Mx6	Racc. équerre 90° 1/4" Mx6	Eckanschluss 90° 1/4" Mx6	Connection 90° 1/4" Mx6
34	T30203 T30207		•	•	•	Elettrovalvola 1/4" 230 V Elettrovalvola 1/4" 110 V	Electrovanne 1/4" 230 V Electrovanne 1/4" 110 V	Magnetventil 1/4" 230 V Magnetventil 1/4" 110 V	Solenoid valve 1/4 230V Solenoid valve 1/4 110V
35	T30204 T30208		•	•	•	Bobina E. V. Parker 230 V Bobina E. V. Parker 110 V	Bobine E. V. Parker 230 V Bobine E. V. Parker 110 V	Spule Parker 230 V Spule Parker 110 V	Solenoid spool Parker 230 V Solenoid spool Parker 110 V
36	I30642		•	•	•	Diaphragma Ø 2,0	Diaphragme Ø 2,0	Düse Ø 2,0	Diaphragm Ø 2,0
37	I30639		•	•	•	Raccordo OT 1/4 M dx-1/4" M sx	Racc. OT 1/4 M dx-1/4" M sx	Eckanschluss OT 1/4 M dx-1/4" M sx	Connection OT 1/4 M dx-1/4" M sx
38	C30342		•	•	•	Passacavo gomma Ø 18	Protection caoutchouc Ø 18	Kabeltülle Ø 18	Protection cable Ø 18
39	T30415		•	•	•	Ugello gas Ø 1,6	Gicleur Ø 1,6	Düse Ø 1,6	Nozzle Ø 1,6
40	I20314		•	•	•	Vite doppia 1/4" M - M	Vis 1/4" M - M	Schraube 1/4" M - M	Screw 1/4" M - M
41	G03092		•	•	•	Supporto quadro elettrico	Support coffret électrique	Steuergerät halterung	Electrical comp. drawer
42	E20305		•	•	•	Morsettiera	Barrette de connection	Klemmreiche	Terminal board
43	E10127		•	•	•	Protezione pl. per pulsante	Protection pour bouton	Schulzschaltknopf	Button plastic profile
44	E30440		•	•	•	Cavo el. c/spina 3 x 1 - 3 m	Cable avec fiche	Kabel mit steckdose	Electric wire with plug
45	E20319		•	•	•	Morsettiera	Barrette de connection	Klemmreiche	Terminal board
46	E10126		•	•	•	Pulsante riarmo	Bouton de rearmement	Reset Knopf	Reset button
47	E40224		•	•	•	Apparecchiatura Brhama DTM 31	Coffret Brhama DTM 31	Steuer. Brhama DTM 31	Ctrl box Brhama DTM 31
48	E10102-P		•	•	•	Commutatore I - 0 - II	Interrupteur I - 0 - II	Schalter I - 0 - II	Switch I - 0 - II
51	E10306 E10321		•	•	•	Fusibile 4 A GT Fusibile 6 A GF	Fusible 4 A GT Fusible 6 A GF	Sicherung 4 A GT Sicherung 6 A GF	Fuse 4 A GT Fuse 6 A GF
54	E20626		•	•	•	Connettore presa 3P + T	Fiche thermostat	Thermostat Stecker	Thermostat plug
55	E20627		•	•	•	Connettore spina 3P + T	Plaque de prise	Steckdoseplatte	Plate plug
56	C30415		•	•	•	Profilo gomma V	V joint	Gummidichtun V	V seal
58	E10213		•	•	•	Elettrodo accensione c/piastrina	Électrode allumage	Zündelektrode	Ignition electrode

Da matr. N. - De matr. No. - Von Masch. Nr. - From number:						GP 60M GP 60A	42401001 44701001		
Pos.	Cod.	€	GP 60M	GP 60A	GP 60M DV	LEGENDA	LEGENDE	NOMENKLATUR	PART LIST
59	E10214			•		Elettrodo ionizzazione c/piastrina	Électrode ionisation	Ionisation Elektrode	Ionisation electrode
60	I30810		•		•	Raccordo bicono 90° 1/4" Fx6	Racc. équerre 90° 1/4" Fx6	Eckanschluss 90° 1/4" Fx6	Connection 90° 1/4" Fx6
61	T30313		•		•	Valvola gas-termica SIT	Vanne thermique SIT	Therموventil SIT	Therموvalve SIT
62	T30315		•		•	Dado M12 per valvola SIT	Ecrou M12 pour vanne SIT	Mutter M12 für ventil SIT	Nut M12 for valve SIT
63	T30314		•		•	Ghiera per valvola SIT	Frette pour vanne SIT	Zwinge für Ventil SIT	Valve bush SIT
64	T30325		•		•	Disgiuntore termico	Disjointer de thermocouple	Abschalter für thermoelement	Breaker circuit thermoelement
65	E50501		•		•	Termocoppia	Thermocouple	Thermoelement	Thermocouple
66	I31005		•		•	Dado M8 per termocoppia	Ecrou M8 pour thermocou.	Mutter M8 für Thermoelem.	Nut M8 for Thermocouple
67	T30603		•		•	Accenditore piezoelettrico	Allumeur électrique	Piezozünder	Piezo-igniter
68	E10110-P		•		•	Interruttore 0 - 1	Interrupteur 0 - 1	Schalter 0 - 1	Switch 0 - 1
69	I40555		•	•	•	Tubo gas c/raccordi 2 m	Tuyau du gaz 2 m	Gasschlauch 2 m	Gas hose 2 m
70	T30308		•	•	•	Valvola stop-gas 10 Kg	Sécurité stop-gaz 10 Kg	Stop-gas Ventil 10 Kg	Excess flow valve 10 Kg
*71	T30302-		•	•	•	Regolatore pressione gas	Manodetendeur	Druckregler	Pressure regulator
72	M20301		•	•	•	Rondella grower Ø 4	Rondelle grower Ø 4	Abstandsring grower Ø 4	Washer grower Ø 4
73	E11135		•	•	•	Filtro antidisturbo DEM	Filtre antipararites DEM	Funk-enstorfilter DEM	Anti-jamming filter DEM
74	C30316		•	•	•	Tappo copritesta Ø 18	Bouchon Ø 18	Gummifuss Ø 18	Plug Ø 18
75	P20142		•	•	•	Telaio supporto	Châssis	Fahrgestell	Frame
76	C10708		•	•	•	Volantino	Vis blocage châssis	Stellschraube	Chassis screw
77	C30313		•	•	•	Sottopiede	Bouchon	Gummifuss	Plug
78	M10108		•	•	•	Vite TCEI M5 x 16	Vis TCEI M5 x 16	Schraube TCEI M5 x 16	Screw TCEI M5 x 16
79	M20408		•	•	•	Dado in gabbia M5	Ecrou M5	Mutter M5	Nut M5
80	M10502		•	•	•	Vite TC 4x3/4"	Vis TC 4x3/4"	Schraube TC 4x3/4"	Screw TC 4x3/4"
81	T10621		•	•	•	Protezione isolante	Protection isolante	Isolierschutz	Insulating profile
82	E50103		•	•	•	Protettore termico V10C	Thermostat bilame	Sicherheitsthermostat	Overheat thermostat
83	G01652		•	•	•	Angolare supporto	Support	Stütze	Support
84	E00206 E00150		•	•	•	Cavo accensione	Cable allumage	Zündungskabel	Switching cable
85	E00302		•	•	•	Cavetto ionizzazione	Cable ionisation	Ionisierungskabel	Ionization cable
86	E00187		•	•	•	Cavo capsula termostatica	Cable thermostat bilame	Thermokapselkabel	Thermostatic capsule cable
87	E20805		•	•	•	Fascetta plastica	Bande plastique	Rohrklemme	Hose clamp
91	G00201		•	•	•	Microinterruttore	Micro-interrupteur	Microschalter	Switch
94	E11125		•	•	•	Relè Finder 65.31 AC	Relais Finder 65.31 AC	Relais Finder 65.31 AC	Relay Finder 65.31 AC
95	G03052		•	•	•	Supporto	Support	Stütze	Support
96	E20406		•	•	•	Protezione per commutatore	Protection pour interrupteur	Schalterschutz	Switch plastic profile
97	E20508		•	•	•	Portafusibile	Porte fusible	Sicherungsschalter	Fuse holder

\* I - Italia; F - Francia; D - Germania; GB - Gran Bretagna; US - USA