

GP 90 A/M

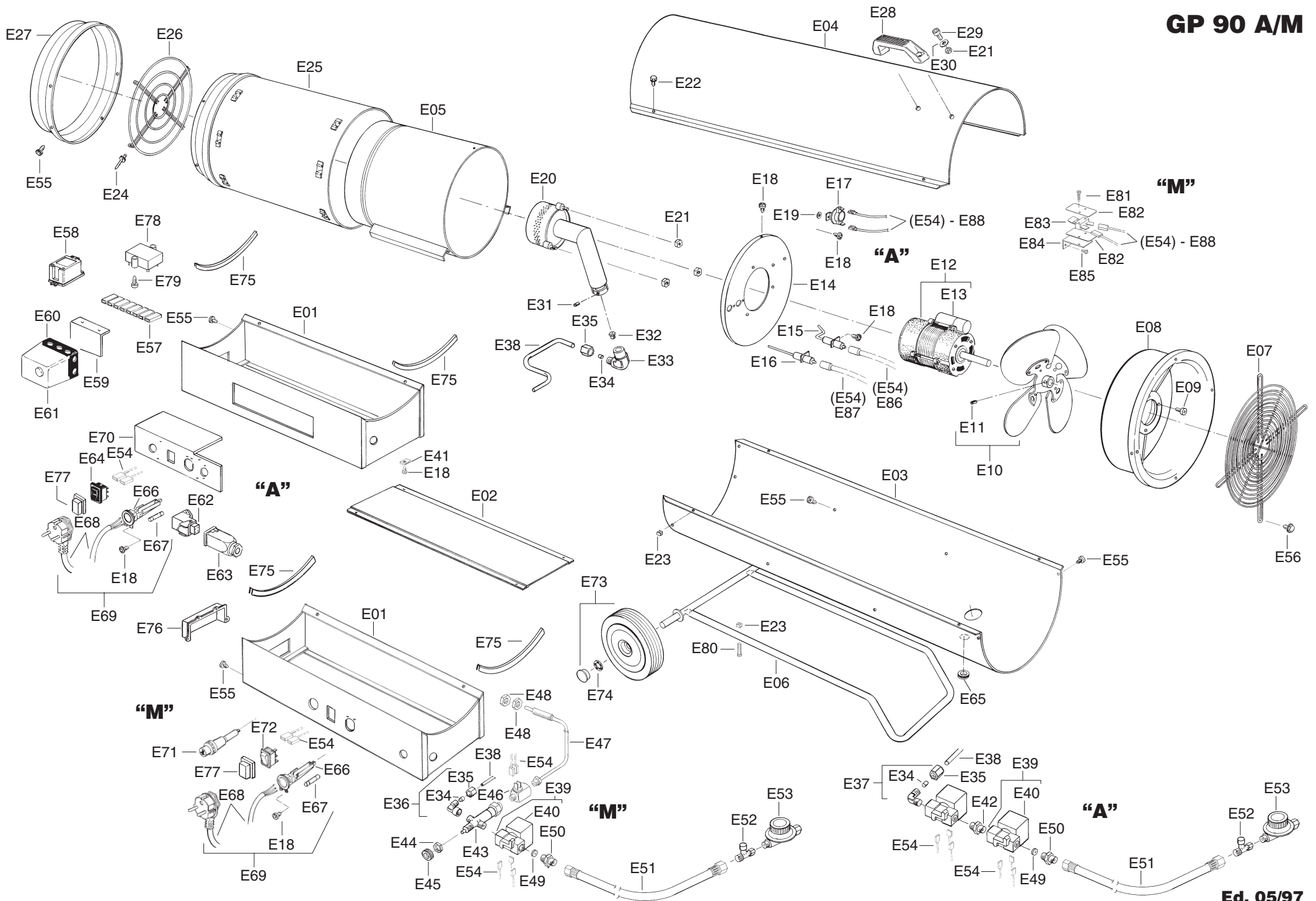

Pos.	Cod.	LEGENDA	LEGENDE	NOMENKLATUR	PART LIST	GP 90M	GP 90A
E 01	G01455	Basamento	Base	Kastenträger	Base	•	
E 01	G01456	Basamento	Base	Kastenträger	Base		•
E 02	G01457	Coperchio quadro elettrico	Couvercle coffret électrique	Inspectiondeckel	Inspection door	•	•
E 03	G01458	Scocca inferiore	Carrosserie inferieur	Karosserie unterteil	Lower body	•	•
E 04	G01459	Scocca superiore	Carrosserie superieur	Haube	Upper body	•	•
E 05	G01460	Camera combustione	Chambre combustion	Brennkammer	Combustion chamber	•	•
E 06	P20124	Telaio supporto	Châssis	Fahrgestell	Frame	•	•
E 07	P30103	Griglia aspirazione	Grille aspiration	Ansauggitter	Inlet grill	•	•
E 08	G01461	Supporto motore	Bride support moteur	Motor Flansch	Motor flange	•	•
E 09	M10306	Vite TCEI M4x16	Vis TCEI M4x16	Schraube TCEI M4x16	Screw TCEI M4x16	•	•
E 10	T10202	Ventola Ø 300 27°	Ventilateur Ø 300 27°	Ventilator Ø 300 27°	Fan Ø 300 27°	•	•
E 11	M10609	Grano M8x8	Vis M8x8	Schraube M8x8	Screw M8x8	•	•
E 12	E10511	Motore 130 W 220/240 V	Moteur 130 W 220/240 V	Motor 130 W 220/240 V	Motor 130 W 220/240 V	•	•
E 13	E11201	Condensatore 5 µF	Condensateur 5 µF	Kondensator 5 µF	Condenser 5 µf	•	•
E 14	G01197	Flangia bruciatore	Bride brûleur	Brenner Teller	Burner plate	•	•
E 15	E10213	Elettrodo accensione c/piastrina	Électrode allumage	Zündelektrode	Ignition electrode	•	•
E 16	E10214	Elettrodo ionizzazione c/piastrina	Électrode ionisation	Ionisation Elektrode	Ionisation electrode		•
E 17	E50102	Capsula termostatica	Thermostat bilame	Ueberhitz Themostat	Overheat thermostat		•
E 18	M10508	Vite TC 8x3/8"	Vis TC 8x3/8"	Schraube TC 8x3/8"	Screw TC 8x3/8"	•	•
E 19	M20107	Rondella Ø 5	Rondelle Ø 5	Abstandsring Ø 5	Washer Ø 5		•
E 20	G01006	Testa di combustione	Brûleur	Brenner	Burner	•	•
E 21	M10704	Dado M6	Ecrou M6	Mutter M6	Nut M6	•	•
E 22	M10513	Vite TC M5x10	Vis TC M5x10	Schraube TC M5x10	Screw TC M5x10	•	•
E 23	M20408	Dado in gabbia	Ecrou	Mutter	Nut	•	•
E 24	M20603	Rivetto Al 4,9x9	Rivet Al 4,9x9	Niet Al 4,9x9	Rivet Al 4,9x9	•	•
E 25	G01462	Involucro camera combustione	Envelope chambre comb.	Brennkammermantel	Combustion chamber cover	•	•
E 26	P30126	Griglia anteriore inox	Grille avant inox	Ausblasgitter	Stainless outlet grill	•	•
E 27	G01463	Cono diffusore	Embout conique	Ausbalskonus	Outlet cone	•	•
E 28	C10202	Maniglia plastica	Poignée	Handgriff	Handle	•	•
E 29	M10316	Vite TCEI M6x14	Vis TCEI M6x14	Schraube TCEI M6x14	Screw TCEI M6x14	•	•
E 30	M20106	Rondella Ø 6	Rondelle Ø 6	Abstandsring Ø 6	Washer Ø 6	•	•
E 31	M10603	Grano M5x8	Vis M5x8	Schraube M5x8	Screw M5x8	•	•
E 32	T30408	Ugello gas Ø 1,9	Gicleur Ø 1,9	Düse Ø 1.9	Nozzle Ø 1.9	•	•
E 33	I30609	Curva portaugello	Raccord pour gicleur	Düse Ekanschluss	Nozzle connection	•	•
E 34	I30809	Bicono Ø 6	Bicône Ø 6	Doppelkegelring Ø 6	Bicone Ø 6	•	•
E 35	I30808	Dado per bicono Ø 6	Ecrou pour bicône Ø 6	Mutter für Doppelkeg. Ø 6	Nut for bicone Ø 6	•	•
E 36	I30810	Raccordo bicono 90° 1/4" Fx6	Racc. équerre 90° 1/4" Fx6	Eckanschluss 90° 1/4" Fx6	Connection 90° 1/4" Fx6	•	
E 37	I30860	Raccordo bicono 90° 1/4" Mx6	Racc. équerre 90° 1/4" Mx6	Eckanschluss 90° 1/4" Mx6	Connection 90° 1/4" Mx6		•
E 38	G01387	Tubo rame sagomato Ø 6	Tuyau cuivre Ø 6	Gaszuführrohr Ø 6	Gas supply pipe Ø 6	•	•
E 39	T30203	Elettrovalvola 1/4" 220 V	Electrovanne 1/4" 220 V	Magnetventil 1/4" 220 V	Solenoid valve 1/4" 220 V	•	•
E 40	T30204	Bobina E. V. Parker 220 V	Bobine E. V. Parker 220 V	Spule Parker 220 V	Solenoid spool Parker 220 V	•	•
E 41	M20402	Piastrina doppia U42-032A	Plaqué elastique U42-032A	Klemmutter U42-032A	Elastic plate U42-032A	•	•
E 42	I20314	Vite doppia 1/4" M - M	Vis 1/4" M - M	Schraube 1/4" M - M	Screw 1/4" M - M		•
E 43	T30313	Valvola gas-termica SIT	Vanne thermique SIT	Thermoventil SIT	Thermal valve SIT	•	

Pos.	Cod.	LEGENDA	LEGENDE	NOMENKLATUR	PART LIST	GP 90M	GP 90A
E 44	T30315	Dado M12 per valvola SIT	Ecrou M12 pour vanne SIT	Mutter M12 für ventil SIT	Nut M12 for valve SIT	•	
E 45	T30314	Ghiera per valvola SIT	Frette pour vanne SIT	Zwinge für Ventil SIT	Valve bush SIT	•	
E 46	T30325	Disgiuntore termico	Disjointer de thermocouple	Abschalter für thermoelement	Breaker circuit thermoelement	•	
E 47	E50501	Termocoppia	Thermocouple	Thermoelement	Thermocouple	•	
E 48	I31005	Dado M8 per termocoppia	Ecrou M8 pour thermocou.	Mutter M8 für Thermoelem.	Nut M8 for Thermocouple	•	
E 49	I30642	Diaframma Ø 2,0	Diaphragme Ø 2,0	Düse Ø 2,0	Diaphragm Ø 2,0	•	•
E 50	I30639	Raccordo OT 1/4 M dx - 1/4" M sx	Racc. OT 1/4 M dx - 1/4" M sx	Eckanschluss OT 1/4 M dx - 1/4" M	Connection OT 1/4 M dx - 1/4" M sx	•	•
E 51	I40555	Tubo gas c/raccordi mt 2	Tuyau du gaz mt 2	Gasschlauch mt 2	Gas hose mt 2	•	•
E 52	T30308	Valvola stop-gas 10 Kg	Sécurité stop-gaz 10 Kg	Stop-gas Ventil 10 Kg	Excess flow valve 10 Kg	•	•
E 53	T30302-*	Regolatore pressione gas	Manodetendeur	Druckregler	Pressure regulator	•	•
E 54	E00141	Cablaggio completo	Cablage complet	Kabel verbindung	Wiring	•	
E 54	E00170	Cablaggio completo	Cablage complet	Kabel verbindung	Wiring		•
E 55	M10508	Vite TC 8x3/8"	Vis TC 8x3/8"	Schraube TC 8x3/8"	Screw TC 8x3/8"	•	•
E 56	M10513	Vite TC M5x10	Vis TC M5x10	Schraube TC M5x10	Screw TC M5x10	•	•
E 57	E20305	Morsettiera	Barrette de connection	Klemmreiche	Terminal board		•
E 58	E10903	Trasformatore A. T.	Transformateur H. T.	Transformator H. T.	Transformer H. T.		•
E 59	G01005	Supporto apparecchiatura	Support	Stütze	Support		•
E 60	E40202	Base per Satronic TFI 812.5	Support Satronic TFI 812.5	Unterlage Satronic TFI 812.5	Box base Satronic TFI 812.5		•
E 61	E40201	Apparecchiatura Satronic TFI 812.5	Coffret Satronic TFI 812.5	Steuerger. Satronic TFI 812.5	Ctrl box Satronic TFI 812.5		•
E 62	E20626	Connettore presa 3P + T	Fiche thermostat	Thermostat Stecker	Thermostat plug		•
E 63	E20627	Connettore spina 3P + T	Plaque de prise	Steckdoseplatte	Plate plug		•
E 64	E10102	Commutatore I - 0 - II	Interrupteur I - 0 - II	Schalter I - 0 - II	Switch I - 0 - II		•
E 65	C30311	Passafilo gomma Ø 35	Protection caoutchouc Ø 35	Kabeltülle Ø 35	Protection cable Ø 35	•	•
E 66	E20307	Morsetto fissacavo	Presse câble	Kabel Führung	Cable fastener	•	•
E 67	E10306	Fusibile 4 A	Fusible 4 A	Sicherung 4 A	Fuse 4 A	•	•
E 68	E30401	Cavo el. 3x1 c/spina	Câble él. avec fiche	Kabel mit steckdose	El. wire with plug	•	•
E 69	E30407	Cavo el. c/spina e morset. fissacavo	Câble él. avec fiche et presse câble	Kabel mit steckdose und kabel Führung	El. wire with plug and cable fastener	•	•
E 70	G01453	Supporto quadro elettrico	Support coffret électrique	Steuergerät halterung	Electrical comp. drawer		•
E 71	T30603	Accenditore piezoelettr. SIT	Allumeur électrique SIT	Piezo-zuender SIT	Piezo-igniter SIT	•	
E 72	E10110	Interruttore 0 - I	Interrupteur 0 - I	Schalter 0 - I	Switch 0 - I	•	
E 73	C10509	Ruota Ø 200 mozzo Ø 20	Roue Ø 200 moyeu Ø 20	Rad Ø 200 Nabe Ø 20	Wheel Ø 200 hub Ø 20	•	•
E 74	M20203	Rondella Block Ø 20	Clips de fixation Ø 20	Radverschluss Ø 20	Wheel holder Ø 20	•	•
E 75	C30414	Profilo gomma V	V joint	Gummidichtung V	V seal	•	•
E 76	E20410	Protezione pl. aspirazione aria	Prise de aspiration d'air	Verbrennungsluftgriff	Air inlet box	•	•
E 77	E20402	Protezione pl. per interruttore	Protection pour interrupteur	Schalterschutz	Switch plastic profile	•	•
E 78	E11130	Filtro antidisturbo	Filtre antipararites	Funk-enstorfilter	Anti-jamming filter		•
E 79	M10514	Vite af TC 4x1/2"	Vis af TC 4x1/2"	Schraube af TC 4x1/2"	Screw af TC 4x1/2"		•
E 80	M10114	Vite M5x30	Vis M5x30	Schraube M5x30	Screw M5x30	•	•
E 81	M10502	Vite TC 4x3/4"	Vis TC 4x3/4"	Schraube TC 4x3/4"	Screw TC 4x3/4"	•	
E 82	T10621	Protezione isolante	Protection isolante	Isolierschutz	Insulating profile	•	
E 83	E50103	Protettore termico V10C	Thermostat bilame	Sicherheitsthermostat	Overheat thermostat	•	
E 84	G01652	Angolare supporto	Support	Stütze	Support	•	
E 85	M10501	Vite TC 4x3/8"	Vis TC 4x3/8"	Schraube TC 4x3/8"	Screw TC 4x3/8"	•	

Pos.	Cod.	LEGENDA	LEGENDE	NOMENKLATUR	PART LIST	GP 90M	GP 90A
E 86	E00150	Cavetto accensione	Cable allumage	Zündungskabel	Switching cable	•	
E 86	E00190	Cavetto accensione	Cable allumage	Zündungskabel	Switching cable		•
E 87	E00183	Cavetto ionizzazione	Cable ionisation	Ionisierungskabel	Ionization cable		•
E 88	E00185	Cavetto capsula term.	Cable thermostat bilame	Thermokapselkabel	Thermostatic capsule cable	•	
E 88	E00187	Cavetto capsula term.	Cable thermostat bilame	Thermokapselkabel	Thermostatic capsule cable		•

* : I - Italia; F - Francia; D - Germania; GB - Gran Bretagna; US - USA

GP 90M	Da matr. n. - De matr. no. - Von masch. nr - From number	41000251
---------------	--	----------