

GP 45 A/M 1996

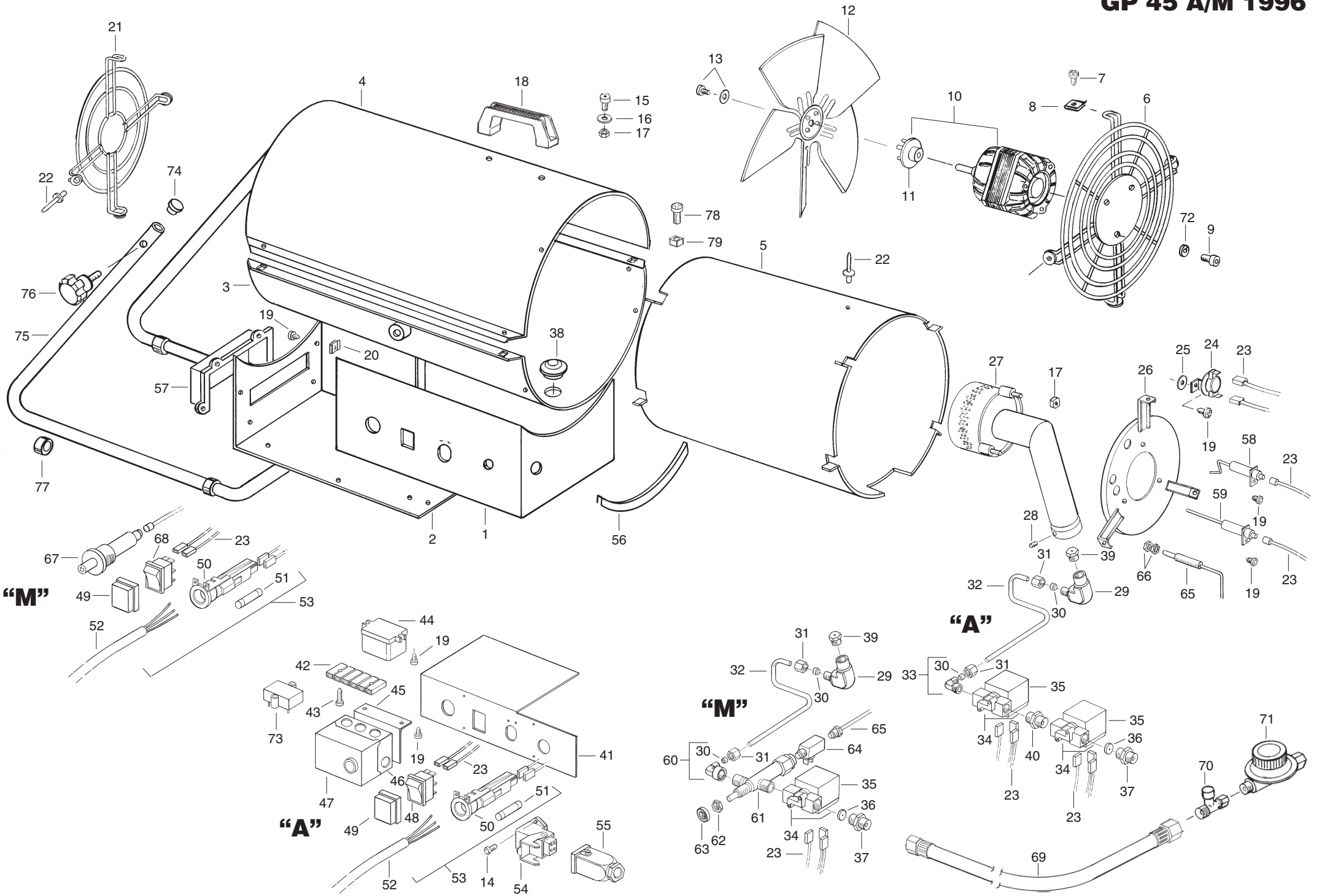

POS.	COD.	LEGENDA	LEGENDE	NOMENKLATUR	PART LIST	GP 45M	GP 45A
	G01519	Basamento	Base	Kastenträger	Base	•	
1	G01520	Basamento	Base	Kastenträger	Base		•
2	G01521	Coperchio quadro elettrico	Couvercle coffret électrique	Inspectiondeckel	inspection door	•	•
3	G01522	Scocca inferiore	Carrosserie inferieur	Karosserie unterteil	Lower body	•	•
4	G01523	Scocca superiore	Carrosserie superieur	Haube	Upper body	•	•
5	G01469	Camera combustione	Chambre combustion	Brennkammer	Combustion chamber	•	•
6	G01384	Griglia aspirazione	Grille aspiration	Ansauggitter	Inlet grill	•	•
7	M10505	Vite TC 8x1/2"	Vis TC 8x1/2"	Schraube TC 8x1/2"	Screw TC8x1/2"	•	•
8	M20412	Piastrina doppia U42-182	Plaqué elastique U42-182	Klemmutter U42-182	Elastic plate U42-182	•	•
9	M10317	Vite TCEI M4x8	Vis TCEI M4x8	Schraube TCEI M4x8	Screw TCEI M4x8	•	•
10	E10547	Motore 82D 4025/7 220/240 V	Moteur 82D 4025/7 220/240 V	Motor 82D 4025/7 220/240 V	Motor 82D 4025/7 220/240 V	•	•
11	C10102	Giunto motore ventola	Accouplement pl. EMI	Plastkupplung EMI	Plastic coupling EMI	•	•
12	T10204	Ventola Ø 300 28	Ventilateur Ø 300 28	Ventilator Ø 300 28	Fan Ø 300 28	•	•
13	M10112	Vite fissaggio ventola EMI	Vis (EMI)	Schraube (EMI)	Screw (EMI)	•	•
14	M10501	Vite TC 4x3/8"	Vis TC 4x3/8"	Schraube TC 4x3/8"	Screw TC 4x3/8"	•	•
15	M10316	Vite TCEI M6 x 14	Vis TCEI M6 x 14	Schraube TCEI M6 x 14	Screw TCEI M6 x 14	•	•
16	M20106	Rondella Ø 6	Rondelle Ø 6	Abstandsring Ø 6	Washer Ø 6	•	•
17	M10704	Dado M6	Ecrou M6	Mutter M6	Nut M6	•	•
18	C10202	Maniglia plastica	Poignée	Handgriff	Handle	•	•
19	M10508	Vite TC 8x3/8"	Vis TC 8x3/8"	Schraube TC 8x3/8"	Screw TC 8x3/8"	•	•
20	M20402	Piastrina doppia U42-032A	Plaqué elastique U42-032A	Klemmutter U42-032A	Elastic plate U42-032A	•	•
21	P30125	Griglia anteriore inox	Grille avant inox	Ausblasgitter	Stainless outlet grill	•	•
22	M20603	Rivetto Al 4,9x9	Rivet Al 4,9x9	Niet Al 4.9x9	Rivet Al 4,9x9	•	•
	E00138	Cablaggio	Cablage	Kabel	Cable	•	
23	E00169	Cablaggio	Cablage	Kabel	Cable		•
24	E50102	Capsula termostatica	Thermostat bilame	Ueberhitz Thermostat	Overheat thermostat	•	•
25	M20107	Rondella Ø 5	Rondelle Ø 5	Abstandsring Ø 5	Washer Ø 5	•	•
26	G01198	Flangia bruciatore	Bride brûleur	Brenner Teller	Burner plate	•	•
27	G01081	Testa di combustione	Brûleur	Brenner	Burner	•	•
28	M10603	Grano M5 x 8	Vis M5 x 8	Schraube M5 x 8	Screw M5 x 8	•	•
29	I30609	Curva portaugello	Raccord pour gicleur	Düse Ekanschluss	Nozzle connection	•	•
30	I30809	Bicono Ø 6	Bicône Ø 6	Doppelkegelring Ø 6	Bicone Ø 6	•	•
31	I30808	Dado per bicono Ø 6	Ecrou pour bicône Ø 6	Mutter für Doppelkeg. Ø 6	Nut for bicone Ø 6	•	•
32	G01385	Tubo rame sagomato Ø 6	Tuyau cuivre Ø 6	Gaszuführrohr Ø 6	Gas supply pipe Ø 6	•	•
33	I30860	Raccordo bicono 90 1/4" Mx6	Racc. équerre 90 1/4" Mx6	Eckanschluss 90 1/4" Mx6	Connection 90 1/4" Mx6		•
34	T30203	Elettrovalvola 1/4" 220 V	Electrovanne 1/4" 220 V	Magnetventil 1/4" 220 V	Solenoid valve 1/4 220V	•	•
35	T30204	Bobina E. V. Parker 220 V	Bobine E. V. Parker 220 V	Spule Parker 220 V	Solenoid spool Parker 220 V	•	•
36	I30641	Diaphragma Ø 1,4	Diaphragme Ø 1,4	Düse Ø 1,4	Diaphragm Ø 1,4	•	•
37	I30639	Raccordo OT 1/4 M dx-1/4" M sx	Racc. OT 1/4 M dx-1/4" M sx	Eckanschluss OT 1/4 M dx-1/4" M sx	Connection OT 1/4 M dx-1/4" M sx	•	•
38	C30310	Passacavo gomma Ø 18	Protection caoutchouc Ø 18	Kabeltülle Ø 18	Protection cable Ø 18	•	•
39	T30407	Ugello gas Ø 1,3	Gicleur Ø 1,3	Düse Ø 1,3	Nozzle Ø 1,3	•	•
40	I20314	Vite doppia 1/4" M - M	Vis 1/4" M - M	Schraube 1/4" M - M	Screw 1/4" M - M		•
41	G01453	Supporto quadro elettrico	Support coffret électrique	Steuergerät halterung	Electrical comp. drawer		•
42	E20305	Morsettiera	Barrette de connection	Klemmreieche	Terminal board		•
43	M10514	Vite TC 4x1/2"	Vite TC 4x1/2"	Schraube TC 4x1/2"	Screw TC 4x1/2"	•	•
44	E10903	Trasformatore A. T.	Transformateur H. T.	Transformator H. T.	Transformer H. T.		•
45	G01005	Supporto apparecchiatura	Support	Stütze	Support		•
46	E40202	Base per Satronic TFI 812.5	Support Satronic TFI 812.5	Unterlage Satronic TFI 812.5	Box base Satronic TFI 812.5		•
47	E40201	Apparecchiatura Satronic TFI 812.5	Coffret Satronic TFI 812.5	Steuerg. Satronic TFI 812.5	Ctrl box Satronic TFI 812.5		•
48	E10102	Commutatore I - 0 - II	Interrupteur I - o - II	Schalter I - 0 - II	Switch I - 0 - II		•
49	E20402	Protezione pl. per interruttore	Protection pour interrupteur	Schalterschutz	Switch plastic profile	•	•
50	E20307	Morsetto fissacavo	Presse câble	Kabel Führung	Cable fastener	•	•
51	E10306	Fusibile 4 A	Fusibile 4 A	Sicherung 4 A	Fuse 4 A	•	•
52	E30401	Cavo el. 3x1 c/spina	Câble él. avec fiche	Kabel mit steckdose	El. wire with plug	•	•
53	E30407	Cavo el. c/spina e morset. fissacavo	Câble él. avec fiche et presse câble	Kabel mit steckdose und kabel Führung	El. wire with plug and cable fastener	•	•
54	E20626	Connettore presa 3P + T	Fiche thermostat	Thermostat Stecker	Thermostat plug		•
55	E20627	Connettore spina 3P + T	Plaque de prise	Steckdoseplatte	Plate plug		•
56	C30415	Profilo gomma V	V joint	Gummidichtun V	V seal	•	•

POS.	COD.	LEGENDA	LEGENDE	NOMENKLATUR	PART LIST	GP 45M	GP 45A
57	E20410	Protezione pl. aspirazione aria	Prise de aspiration d'air	Verbrennungsluftgriff	Air inlet box	•	•
58	E10213	Elettrodo accensione c/piastrina	Électrode allumage	Zündelektrode	Ignition electrode	•	•
59	E10214	Elettrodo ionizzazione c/piastrina	Électrode ionisation	Ionisation Elektrode	Ionisation electrode		•
60	I30810	Raccordo bicono 90 1/4" Fx6	Racc. équerre 90 1/4" Fx6	Eckanschluss 90 1/4" Fx6	Connection 90 1/4" Fx6	•	
61	T30313	Valvola gas-termica SIT	Vanne thermique SIT	Thermovenil SIT	Thermovalve SIT	•	
62	T30315	Dado M12 per valvola SIT	Ecrou M12 pour vanne SIT	Mutter M12 für ventil SIT	Nut M12 for valve SIT	•	
63	T30314	Ghiera per valvola SIT	Frette pour vanne SIT	Zwinge für Ventil SIT	Valve bush SIT	•	
64	T30325	Disgiuntore termico	Disjointer de thermocouple	Abschalter für thermoelement	Breaker circuit thermoelement	•	
65	E50501	Termocoppia	Thermocouple	Thermoelement	Thermocouple	•	
66	I31005	Dado M8 per termocoppia	Ecrou M8 pour thermocou.	Mutter M8 für Thermoelem.	Nut M8 for Thermocouple	•	
67	T30603	Accenditore piezoelettr. SIT	Allumeur électrique SIT	Piezo-zuender SIT	Piezo-igniter SIT	•	
68	E10110	Interruttore 0 - I	Interrupteur 0 - I	Schalter 0 - 1	Switch 0 - I	•	
69	I40554	Tubo gas c/raccordi 1,5 m	Tuyau du gaz 1,5 m	Gasschlauch 1,5 m	Gas hose 1,5 m	•	•
70	T30307	Valvola stop-gas 6 Kg	Sécurité stop-gaz 6 Kg	Stop-gas Ventil 6 Kg	Excess flow valve 6 Kg	•	•
71	T30302-*	Regolatore pressione gas	Manodetendeur	Druckregler	Pressure regulator	•	•
72	M20301	Rondella grower Ø 4	Rondelle grower Ø 4	Abstandsring grower Ø 4	Washer grower Ø 4	•	•
73	E11130	Filtro antidisturbo	Filtre antipararites	Funk-enstorfilter	Anti-jamming filter		•
74	C30316	Tappo copritesta Ø 18	Bouchon Ø 18	Gummifuss Ø 18	Plug Ø 18	•	•
75	P20123	Telaio supporto	Châssis	Fahrgestell	Frame	•	•
76	C10707	Volantino	Vis blocage châssis	Stellschraube	Chassis screw	•	•
77	C30313	Sottopiede	Bouchon	Gummifuss	Plug	•	•
78	M10113	Vite TCEI M5 x 10	Vis TCEI M5 x 10	Schraube TCEI M5 x 10	Screw TCEI M5 x 10	•	•
79	M20408	Dado in gabbia M5	Ecrou M5	Mutter M5	Nut M5	•	•

* : I - Italia; F - Francia; D - Germania; GB - Gran Bretagna