

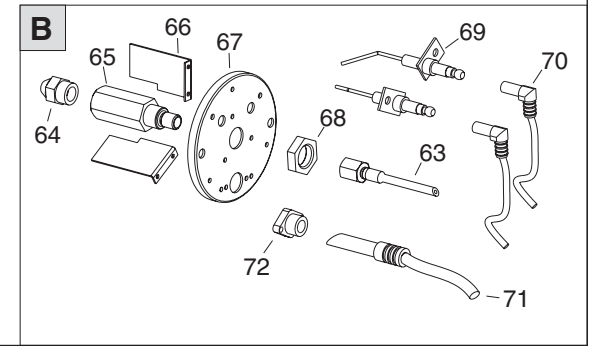

**EC**

**EC 22 - EC 32**  
**EC 22 DV - EC 32 DV**

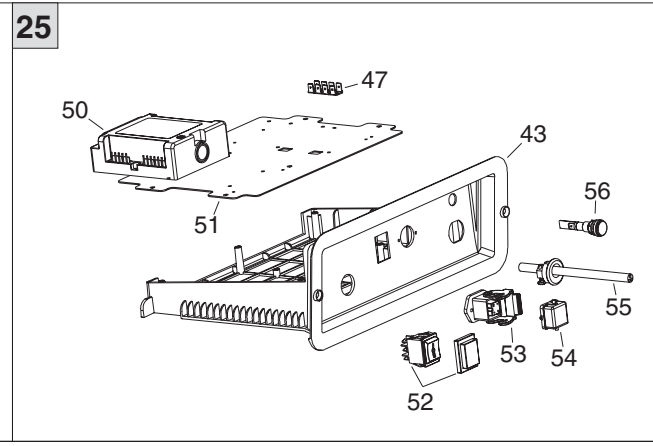
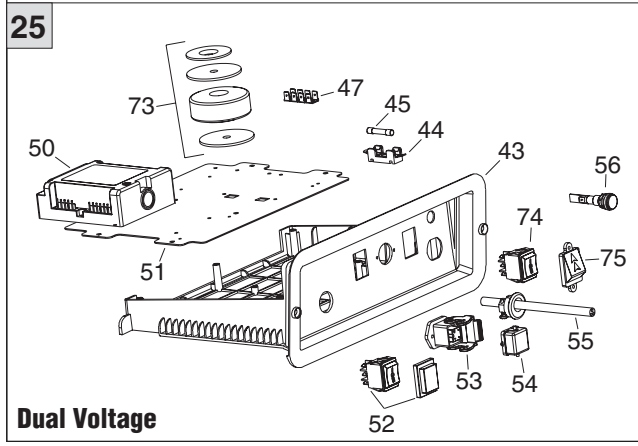
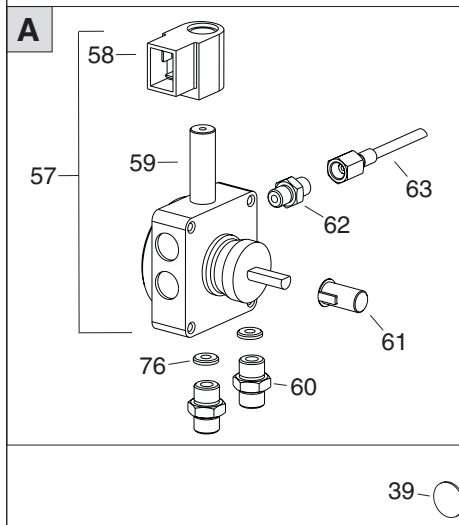
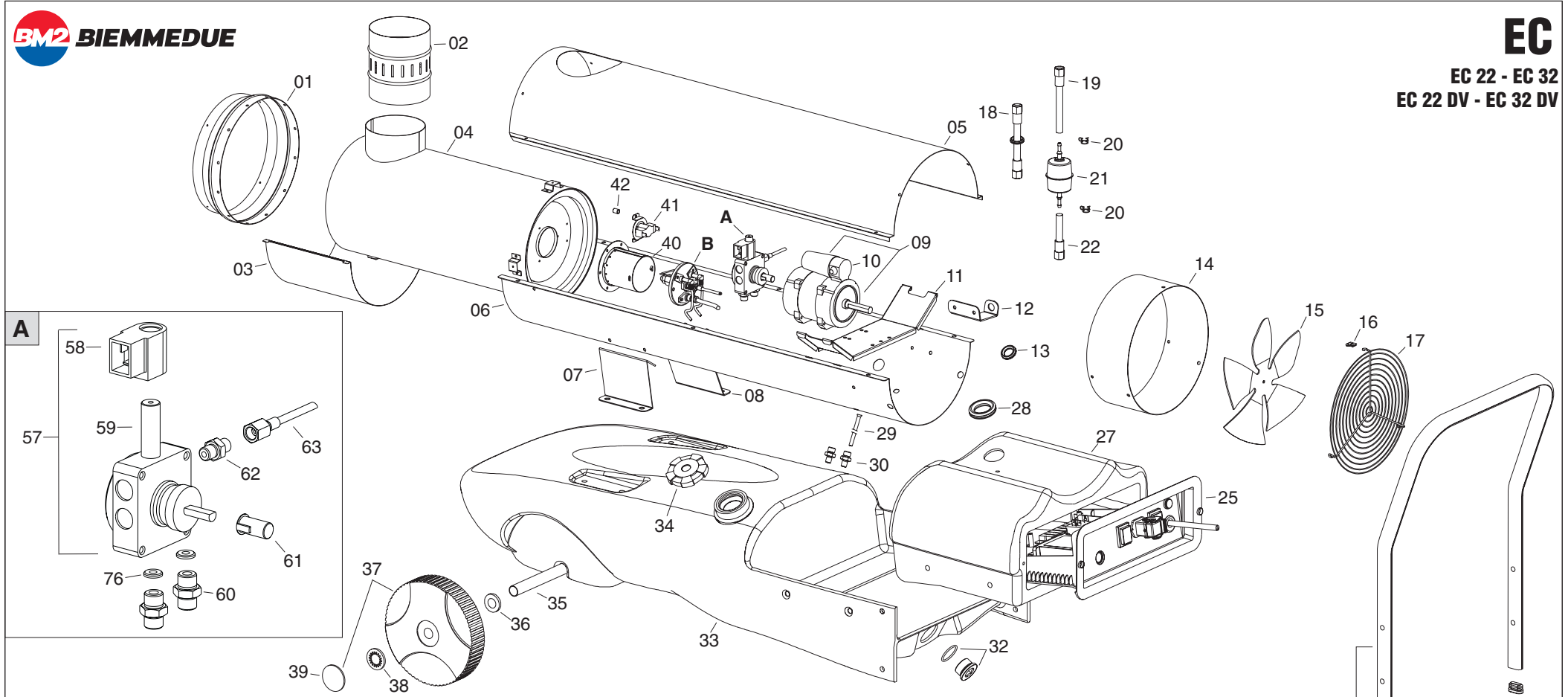

Da matr. N. - De matr. No. - Von Masch. Nr. - From number:

EC 22  
EC 3220600401  
20700201

Pos.	Cod.	€	EC 22	EC 22 DV	EC 32	EC 32 DV	LEGENDA	LEGENDE	NOMENKLATUR	PART LIST
01	G06074-3001 G06075-3001		•	•	•	•	Cono diffusore	Embout conique	Ausblaskonus	Outlet cone
02	G06076 G06077		•	•	•	•	Raccordo camino Ø 120 Raccordo camino Ø 150	Cheminée Ø 120 Cheminée Ø 150	Kamin Ø 120 Kamin Ø 150	Chimney Ø 120 Chimney Ø 150
03	G06078 G06079		•	•	•	•	Protezione camera combustione	Protection chambre de combustion	Brennkammerabdeckblech	Combustion chamber support
04	G06080 G06081		•	•	•	•	Camera di combustione	Chambre de combustion	Brennkammer	Combustion chamber
05	G06082-3001 G06083-3001		•	•	•	•	Scocca superiore	Carrosserie sup.	Haube	Upper body
06	G06084-3001 G06085-3001		•	•	•	•	Scocca inferiore	Carrosserie Inf.	Karosserie Unterteil	Lower body
07	G06065-9005		•	•	•	•	Staffa supporto carrozzeria SX	Étrier support carrosserie gauche	Haltebügel Verkleidung links	Left chassis support bracket
08	G06088-9005		•	•	•	•	Staffa supporto carrozzeria DX	Étrier support carrosserie droit	Haltebügel Verkleidung rechts	Right chassis support bracket
09	E10677 E10687		•	•	•	•	Motore 200W c/condens. Motore 110W c/condens.	Moteur 200W avec condensateur Moteur 110W avec condensateur	Motor 200W mit Kondensator Motor 110W mit Kondensator	Motor 200W with condenser Motor 110W with condenser
10	E11214 E11204		•	•	•	•	Condensatore 6,3 µF Condensatore 4 µF	Condensateur 6,3 µF Condensateur 4 µF	Kondensator 6,3 µF Kondensator 4 µF	Condenser 6,3 µF Condenser 4 µF
11	G06066 G06067		•	•	•	•	Supporto motore ventola	Bride support moteur	Motor Flansch	Motor flange
12	G06068-9005		•	•	•	•	Gancio cavo alimentazione	Crochet câble d'alimentation	Haken Netzkabel	Power lead hook
13	C30352		•	•	•	•	Passacavo Ø15	Protection cable Ø15	Kabeltülle Ø15	Cable protection Ø15
14	G06069-3001 G06070-3001		•	•	•	•	Anello protezione ventilatore	Anneau protection ventilateur	Ring Schutzeinrichtung Ventilator	Fan protection ring
15	T10253 T10207		•	•	•	•	Ventola Ø 235 30° Ventola Ø 300 18°	Ventilateur Ø 235 30° Ventilateur Ø 300 18°	Ventilator Ø 2305 35° Ventilator Ø 300 18°	Fan Ø 235 30° Fan Ø 300 18°
16	M20402		•	•	•	•	Piastrina doppia U42-032	Plaque elastique U42-032	Klemmutter U42-032	Elastic Plate U42-032
17	P30161 P30165		•	•	•	•	Griglia aspirazione	Grille protection	Schutzgitter	Inlet grille
18	I40328		•	•	•	•	Tubo BP 1/4" F L.300mm	Tube BP 1/4" F L.300mm	Rohr BP 1/4" F L.300mm	Tube BP 1/4" F L.300mm
19	I40327		•	•	•	•	Tubo BP 1/4" F L.180mm	Tube BP 1/4" F L.180mm	Rohr BP 1/4" F L.180mm	Tube BP 1/4" F L.180mm
20	C30729		•	•	•	•	Fascetta per tubo	Collier	Schelle	Clamp
21	I30414		•	•	•	•	Filtro gasolio compl.	Filtere avec cartouche	Filter komp.	Filter with cartridge
22	I40326		•	•	•	•	Tubo BP 1/4" F L.85mm	Tube BP 1/4" F L.85mm	Rohr BP 1/4" F L.85mm	Tube BP 1/4" F L.85mm
23	P20173-9005		•	•	•	•	Maniglia/Piede	Poignée/Support	Handgriff/Stütze	Handle/Support
24	C30361		•	•	•	•	Tappo copritesta	Bouchon	Gummifuss	Plug
25	G00225 G00236		•	•	•	•	Quadro elettrico	Coffret électrique	Elektrokasten	El. componets drawer
27	P50128 P50129		•	•	•	•	Protezione quadro elettrico	Protection tableau électrique	Schutzeinrichtung Schaltschrank	Electrical switchboard protection
28	C30307		•	•	•	•	Passatubo gomma Ø 35	Prot. caoutchouc Ø 35	Kabeltülle Ø 35	Protection cable Ø 35
29	I30696		•	•	•	•	Pescante L.220mm	Pascante L.220mm	Pascante L.220mm	Pascante L.220mm
30	I30737		•	•	•	•	Nipplo OT 1/4" M - M12x1,75 M	Nipplo OT 1/4" M - M12x1,75 M	Nipplo OT 1/4" M - M12x1,75 M	Nipplo OT 1/4" M - M12x1,75 M
32	C30370		•	•	•	•	Tappo Serbatoio M30x1,5	Réservoir fuel	Tank	Fuel tank
33	P50130		•	•	•	•	Serbatoio gasolio	Réservoir fuel	Tank	Fuel tank
34	C30356		•	•	•	•	Tappo bocchettone	Bouchon	Pfropfen	Drain plug
35	P20179-9005		•	•	•	•	Assale	Essieu	Achse	Wheel axle
36	M20110		•	•	•	•	Rondella Ø21 x Ø37 x 3	Rondelle Ø21 x Ø37 x 3	Abstandsring Ø21 x Ø37 x 3	Washer Ø21 x Ø37 x 3
37	C10543		•	•	•	•	Ruota Ø 200 - Ø 20	Roue Ø 200 - Ø 20	Rad Ø 200 - Ø 20	Wheel Ø 200 - Ø 20
38	M20203		•	•	•	•	Rondella el. block Ø 20	Clips de fixation Ø 20	Radverschluss Ø 20	Wheel holder Ø 20
39	C10513-R		•	•	•	•	Borchia Pl. Rossa	Cabocon	Deckel	Cover
40	G06086 G06087		•	•	•	•	Boccaglio	Gueulard	Brennrohr	Blast tube
41	E50102		•	•	•	•	Capsula termostatica Fan	Thermostat bilame Fan	Thermostat Fan	Fan Thermostat
42	G06072		•	•	•	•	Distanziale Ø8 x Ø6 x 9,5	Epaisseur Ø8 x Ø6 x 9,5	Abstandsstück Ø8 x Ø6 x 9,5	Sleeve Ø8 x Ø6 x 9,5
43	G06153 G06155		•	•	•	•	Supporto quadro elettrico	Support coffret électrique	Steuergeräthalerung	Electr. componets drawer
44	E20508		•	•	•	•	Porta fusibile	Porte fusible	Sicherungsschalter	Fuse holder
45	E10307		•	•	•	•	Fusibile vetro (6x30) 6,3A	Fusible (6x30) 6,3A	Sicherung (6x30) 6,3A	Fuse (6x30) 6,3A
47	E20319		•	•	•	•	Morsettiera terra	Barrette de connection	Klemmreiche	Terminal board
50	E40122		•	•	•	•	Apparecchiatura BRAHMA TGRD 71	Coffret BRAHMA TGRD 71	Steuergerät BRAHMA TGRD 71	Control box BRAHMA TGRD 71

Da matr. N. - De matr. No. - Von Masch. Nr. - From number:

EC 22

20600401

EC 32

20700201

Pos.	Cod.	€	EC 22	EC 22 DV	EC 32	EC 32 DV	LEGENDA	LEGENDE	NOMENKLATUR	PART LIST
51	G06073		•	•	•	•	Piastra supporto elementi elettrici	Plaqu support	Tragplatte für elektrische Teile	Plate for electrical components
52	E10102-P		•	•	•	•	Interruttore bipolare 0 - 1	Interrupteur 0 - 1	Schalter 0 - 1	Switch 0 - 1
53	E20640		•	•	•	•	Connettore presa 3P+T	Fiche thermostat 3P+T	Thermostat stecker 3P+T	Thermostat plug 3P+T
54	E20665		•	•	•	•	Tappo	Bouchon	Pfropfen	Drain plug
55	E30440 E30445		•	•	•	•	Cavo elettrico c/spina e morsettieria	Câble avec fiche et presse câble	Kabel mit steckdose und kabel Führung	El. wire with plug and cable fastener
56	E11030		•	•	•	•	Lampada 230V	Lampe 230V	Kontrollampe 230V	Lamp 230V
57	T20429		•	•	•	•	Pompa Danfoss BFP01	Pompe Danfoss BFP01	Pumpe Danfoss BFP01	Pump Danfoss BFP01
58	T20114		•	•	•	•	Bobina E.V. BFP Danfoss	Bobine E.V. BFP Danfoss	Spule BFP Danfoss	Solenoid spool BFP Danfoss
59	T20117		•	•	•	•	Corpo E.V. Danfoss	Electrovanne Danfoss	Magnetventil Danfoss	Solenoid valve Danfoss
60	I20104		•	•	•	•	Nipplo FE 1/4" MM	Nipplo FE 1/4" MM	Nipplo FE 1/4" MM	Nipplo FE 1/4" MM
61	E10513		•	•	•	•	Giunto Pl. mot.-pompa K1	Accouplement Pl. K1	PlastikKuplung K1	Coupling K1
62	I20115		•	•	•	•	Nipplo FE 1/8" MM	Nipplo FE 1/8" MM	Nipplo FE 1/8" MM	Nipplo FE 1/8" MM
63	I40192		•	•	•	•	Microtubo	Microtube	Microschlauch	Micropipe
64	T20338 T20339		•	•	•	•	Ugello 0,40 GPH 80° S Ugello 0,60 GPH 80° S	Gicleur 0,40 GPH 80° S Gicleur 0,60 GPH 80° S	Düse 0,40 GPH 80° S Düse 0,60 GPH 80° S	Nozzle 0,40 GPH 80° S Nozzle 0,60 GPH 80° S
65	I33001		•	•	•	•	Canotto portaugello	Support gicleur	Düsehalter	Nozzle support
66	G06042		•	•	•	•	Convogliatore aria per bruciatore	Défecteur d'air brûleur	Luftleitblech für brenner	Air flap for burner
67	P20528 P20526		•	•	•	•	Flangia supp. Bruciatore Ø 80mm	Bride Brûleur Ø 80mm	Brenner Flansch Ø 80mm	Burner flange Ø 80mm
68	I31034		•	•	•	•	Controdado OT. M14	Ecrou M14	Mutter M14	Nut M14
69	E10248		•	•	•	•	Elettrodo c/piastrina	Électrode	Elektrode	Electrode
70	G02075		•	•	•	•	Cavo A.T. L.1000m	Conn. câble 90° H.T.	H.S. Anschluß 90°	H.T. Cable connect. 90°
71	E50325		•	•	•	•	Fotoresistenza BRAHMA FC 11	Photoresis. BRAHMA FC 11	Fotozelle BRAHMA FC 11	Ld ph. Unit BRAHMA FC 11
72	E50325-FL		•	•	•	•	Flangia Fotoresistenza	Bride	Fotozelle Flansch	Flange
73	E10836		•	•	•	•	Trasformatore 400 VA	Transformateur 400 VA	Zündtrafo 400 VA	Transformer 400 VA
74	E10110N-P		•	•	•	•	Commutatore I - II	Interrupteur I - II	Schalter I - II	Switch I - II
75	E20406		•	•	•	•	Protezione per commutatore	Protection pour interrupteur	Schalterschutz	Switch plastic profile
76	M20123		•	•	•	•	Rondella 1/4"	Rondelle 1/4"	Abstandsring 1/4"	Washer 1/4"