

Ed. 04/04

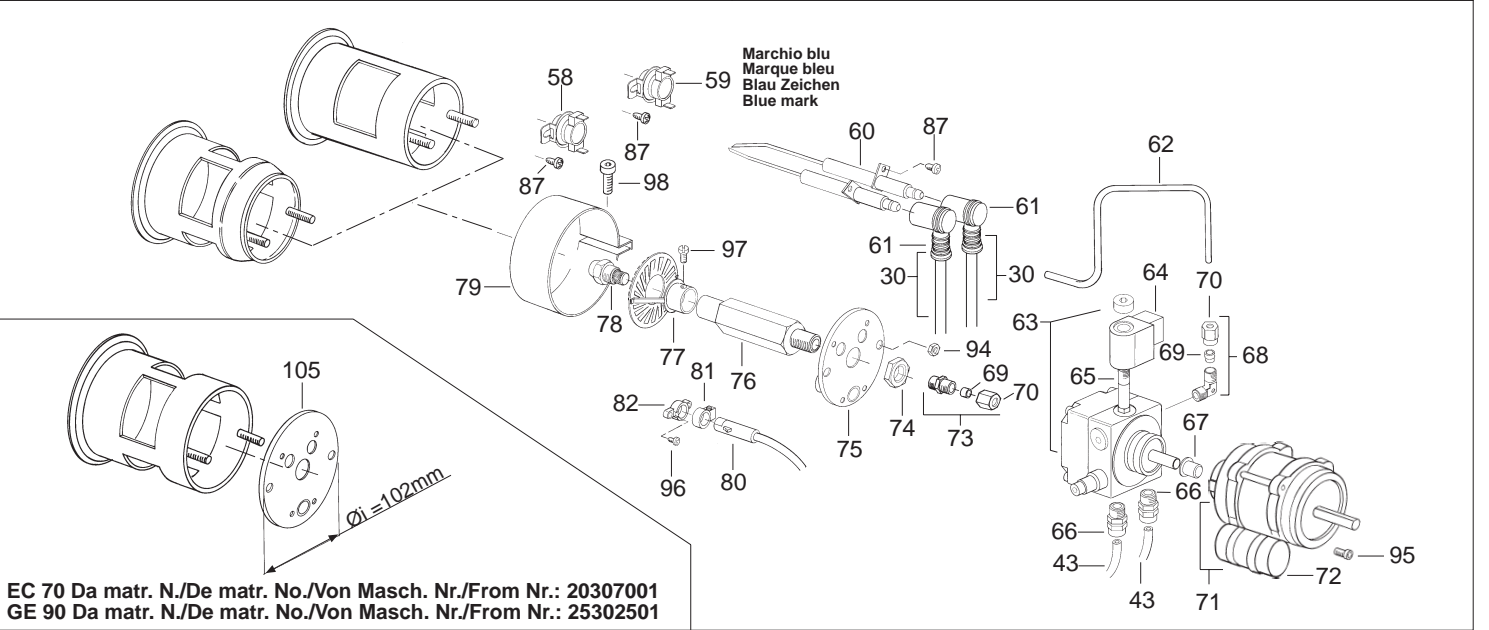

EC 70 Da matr. N./De matr. No./Von Masch. Nr./From Nr.: 20307001
 GE 90 Da matr. N./De matr. No./Von Masch. Nr./From Nr.: 25302501

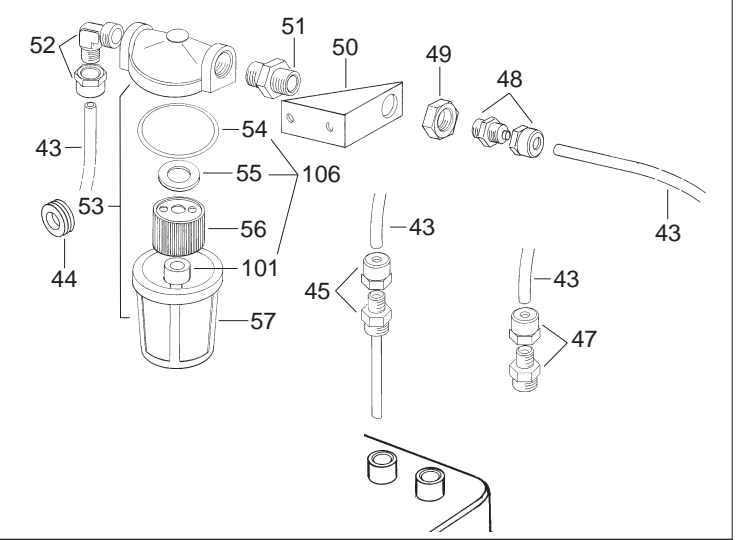
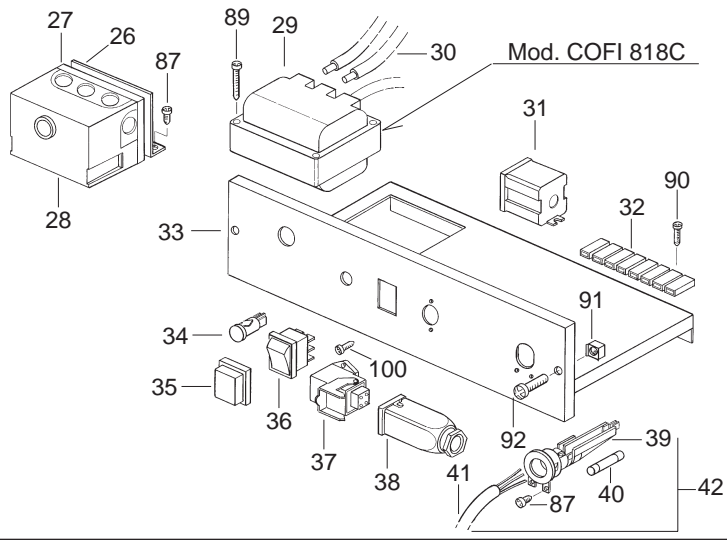