

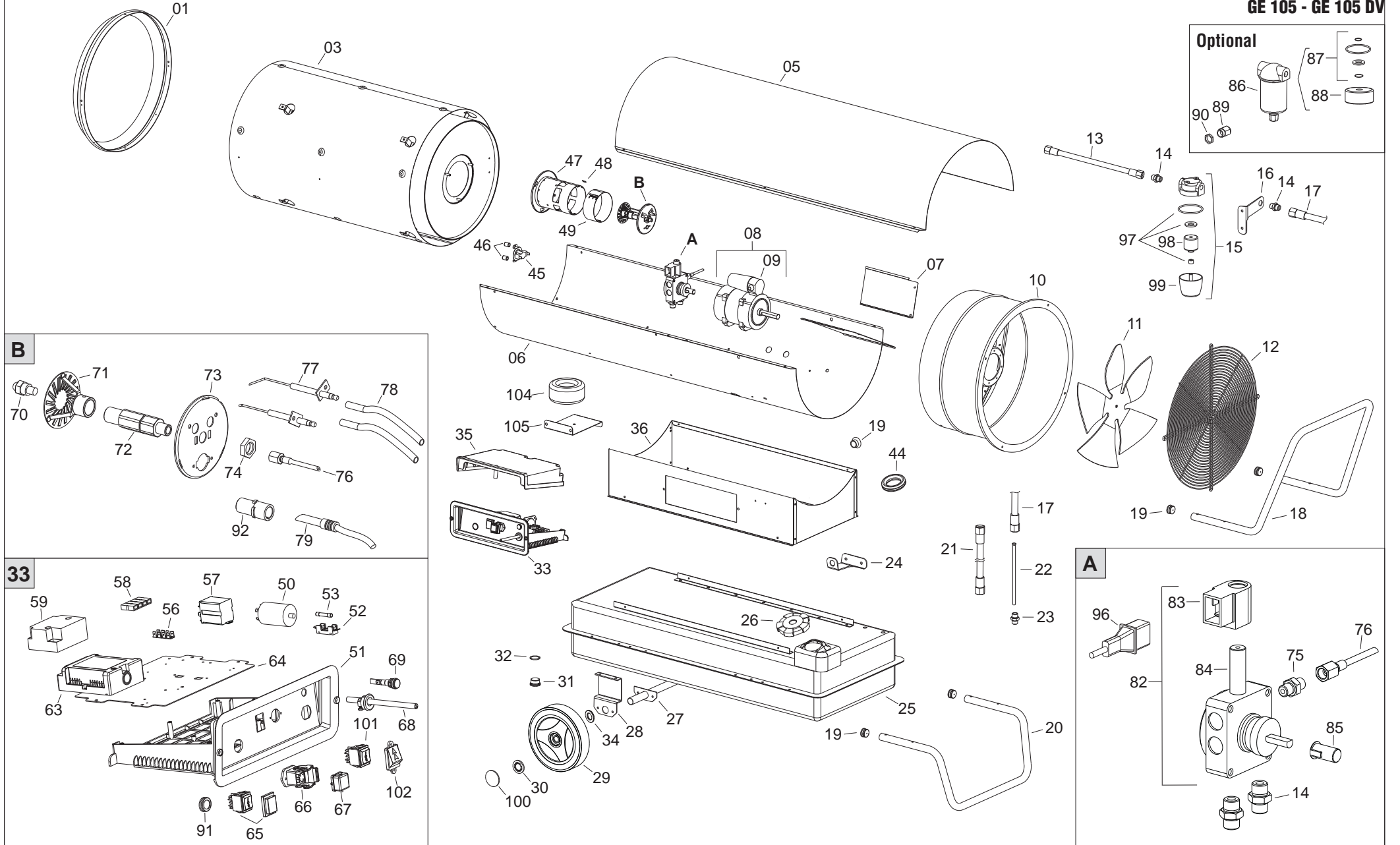

GE

GE 105 - GE 105 DV



Da matr. N. - De matr. No. - Von Masch. Nr. - From number:				GE 105		27300301		
Pos.	Cod.	€	GE 105	GE 105 DV	LEGENDA	LEGENDE	NOMENKLATUR	PART LIST
01	G06139-3001		•	•	Cono diffusore	Embout conique	Ausblaskonus	Outlet cone
03	G06231		•	•	Camera di combustione	Chambre de combustion	Brennkammer	Combustion chamber
05	G06234-3001		•	•	Scocca superiore	Carrosserie sup.	Haube	Upper body
06	G06237-3001		•	•	Scocca inferiore	Carrosserie Inf.	Karosserie Unterteil	Lower body
07	G06240		•	•	Convogliatore aria	Défecteur d'air	Luftleiblech	Air flap

AACO

08	E10679 E10679-110		•	•	Motore 750W c/condens. Motore 750W c/condens.	Moteur 750W avec condensateur Moteur 750W avec condensateur	Motor 750W mit Kondensator Motor 750W mit Kondensator	Motor 750W with condenser Motor 750W with condenser
09	E11232 E11241		•	•	Condensatore 20 µF Condensatore 90 µF	Condensateur 20 µF Condensateur 90 µF	Kondensator 20 µF Kondensator 90 µF	Condenser 20 µF Condenser 90 µF

SIMEL

08	E10694		•	•	Motore 750W c/condens.	Moteur 750W avec condensateur	Motor 750W mit Kondensator	Motor 750W with condenser
09	E11244		•	•	Condensatore 20 µF	Condensateur 20 µF	Kondensator 20 µF	Condenser 20 µF
10	G06239-3001		•	•	Supporto motore ventola	Bride support moteur	Motor Flansch	Motor flange
11	T10201		•	•	Ventola Ø 500 33°	Ventilateur Ø 500 33°	Ventilator Ø 500 33°	Fan Ø 500 33°
12	P30129		•	•	Griglia aspirazione	Grille protection	Schutzgitter	Inlet grille
13	I40330		•	•	Tube BP 1/4" FF L.420 mm	Tube BP 1/4" FF L.420mm	Rohr BP 1/4" FF L.420mm	Tube BP 1/4" FF L.420mm
14	I20104		•	•	Nipplo FE 1/4" MM	Nipplo FE 1/4" MM	Nipplo FE 1/4" MM	Nipplo FE 1/4" MM
15	T20201		•	•	Filtro gasolio compl.	Filtre avec cartouche	Filter komp.	Filter with cartidge
16	G06104-9005		•	•	Supporto filtro	Support	Stütze	Filter support
17	I40329		•	•	Tube BP 1/4" FF L.260mm	Tube BP 1/4" FF L.260mm	Rohr BP 1/4" FF L.260mm	Tube BP 1/4" FF L.260mm
18	P20176-9005		•	•	Maniglia	Poignée	Handgriff	Handle
19	C30319		•	•	Tappo copritesta Ø25	Bouchon Ø25	Gummifuss Ø25	Plug Ø25
20	P20177-9005		•	•	Piede	Pied	Fuß	Foot
21	I40331		•	•	Tube BP 1/4" F L.580 mm.	Tube BP 1/4" F L.580mm	Rohr BP 1/4" F L.580mm	Tube BP 1/4" F L.580mm
22	I30696		•	•	Pescante L.220mm	Pascante L.220mm	Pascante L.220mm	Pascante L.220mm
23	I30737		•	•	Nipplo OT 1/4" M - M12x1,75 M	Nipplo OT 1/4" M - M12x1,75 M	Nipplo OT 1/4" M - M12x1,75 M	Nipplo OT 1/4" M - M12x1,75 M
24	G06068-9005		•	•	Gancio cavo alimentazione	Crochet câble d'alimentation	Haken Netzkabel	Power lead hook
25	G06128-9005		•	•	Seratoio gasolio 105 l	Réservoir fuel 105 l	Tank 105 l	Fuel tank 105 l
26	C30356		•	•	Tappo bocchettone	Bouchon	Pfropfen	Drain plug
27	G06138-9005		•	•	Assale	Essieu	Achse	Wheel axle
28	G06106-9005		•	•	Staffa su assale ruote	Support on essieu roues	Bügel auf der elektrische Achse	Wheels axle support
29	C10544		•	•	Ruota Ø 250 - Ø 20	Roue Ø 250 - Ø 20	Rad Ø 250 - Ø 20	Wheel Ø 250 - Ø 20
30	M20203		•	•	Rondella el. block Ø 20	Clips de fixation Ø 20	Radverschluss Ø 20	Whell holder Ø 20
31	I25020		•	•	Tappo Seratoio M16x1,5	Bouchon de vidange	Ablass Propfen Oel	Drain plug
32	C30375		•	•	OR Ø16 x 2,62	OR Ø16 x 2,62	OR Ø16 x 2,62	OR Ø16 x 2,62
33	G00255		•	•	Quadro elettrico	Coffret électrique	Elektrokasten	El. componets drawer
34	M20110		•	•	Rondella Ø21 x Ø37 x 3 mm	Rondelle Ø21 x Ø37 x 3 mm	Abstandsring Ø21 x Ø37 x 3 mm	Washer Ø21 x Ø37 x 3 mm
35	P50127		•	•	Copertura quadro elettrico	Couverture coffret électrique	Abdeckung Schalttöfel	Control box cover
36	G06152-3001		•	•	Basamento	Base	Kastenträger	Base
44	C30372		•	•	Passatubo gomma Ø 35	Prot. caoutchouc Ø 35	Kabeltülle Ø 35	Protection cable Ø 35
45	E50102		•	•	Capsula termostatica Limit	Thermostat bilame Limit	Thermostat Limit	Limit Thermostat
46	G06072		•	•	Distanziale Ø8 x Ø6 x 9,5	Epaisseur Ø8 x Ø6 x 9,5	Abstandsstück Ø8 x Ø6 x 9,5	Sleeve Ø8 x Ø6 x 9,5
47	G06249		•	•	Boccaglio	Gueulard	Brennrohr	Blast tube
48	E20671		•	•	Morsettiera terra	Barrette de connection	Klemmreiche	Terminal board
49	G06183		•	•	Anello regolazione aria	Volet réglage air	Brennluftklappe	Air regulatoin flap
50	E11135		•	•	Filtro antidisturbo DEM	Filtre atipararites DEM	Funk-enstorfilter DEM	Anti-jamming filter DEM
51	G06153		•	•	Supporto quadro elettrico	Support coffret électrique	Steuergeräthalerung	Electr. componets drawer
52	E20508		•	•	Porta fusibile	Porta fusible	Sicherungschalter	Fuse holder
53	E10308		•	•	Fusibile (6x30) 10A	Fusible (6x30) 10A	Sicherung (6x30) 10A	Fuse (6x30) 10A
56	E20319		•	•	Morsettiera terra	Barrette de connection	Klemmreiche	Terminal board
57	E11120		•	•	Relè Finder 65.31 AC	Relais Finder 65.31 AC	Relais Finder 65.31 AC	Relay Finder 65.31 AC
58	E20305		•	•	Morsettiera	Barrette de connection	Klemmreiche	Terminal board
59	E10920		•	•	Trasformatore A.T. TRK1 230V	Transformateur H.T. TRK1 230V	Zündtrafo H.T. TRK1 230V	Transformer H.T. TRK1 230V
63	E40126		•	•	Apparechiatura BRAHMA TGRD 91 230V	Coffret BRAHMA TGRD 91 230V	Steuergerät BRAHMA TGRD 91 230V	Control box BRAHMA TGRD 91 230V
64	G06073		•	•	Piastra supporto elementi elettrici	Plaqu support	Tragplatte für elektrische Teile	Plate for electrical components
65	E10102-P		•	•	Interruttore bipolare 0 - 1	Interrupteur 0 - 1	Schalter 0 - 1	Switch 0 - 1

Da matr. N. - De matr. No. - Von Masch. Nr. - From number:

GE 105

27300301

Pos.	Cod.	€	GE 105	GE 105 DV	LEGENDA	LEGENDE	NOMENKLATUR	PART LIST
66	E20614		•	•	Connettore presa 3P+T	Fiche thermostat 3P+T	Thermostat stecker 3P+T	Thermostat plug 3P+T
67	E20665		•	•	Tappo	Bouchon	Pfropfen	Drain plug
68	E30446		•	•	Cavo elettrico c/spina e pressacavo	Câble avec fiche et presse câble	Kabel mit steckdose und kabelpresse	El. wire with plug and cable fastener
69	E11030		•	•	Lampada 230V	Lampe 230V	Kontrolllampe 230V	Lamp 230V
70	T20357		•	•	Ugello 2,00 GPH 80° W	Gicleur 2,00 GPH 80° W	Düse 2,0 GPH 80° W	Nozzle 2,00 GPH 80° W
71	G01077		•	•	Deflettore centrato	Accroche flamme	Stauscheibe	Turbo disc
72	I33005		•	•	Cannotto portaugello	Support gicleur	Düsehalter	Nozzle support
73	G06228		•	•	Flangia supp. Bruciatore Ø 102mm	Bride Brûleur Ø 102mm	Brenner Flansch Ø 102mm	Burner flange Ø 102mm
74	I31034		•	•	Controdado OT. M14	Ecrou M14	Mutter M14	Nut M14
75	I20115		•	•	Nipplo FE 1/8" MM	Nipplo FE 1/8" MM	Nipplo FE 1/8" MM	Nipplo FE 1/8" MM
76	I40192		•	•	Microtubo	Microtubo	Microschlauch	Micropipe
77	E10215		•	•	Elettrodo c/piastrina	Électrode	Elektrode	Electrode
78	G02075		•	•	Cavo A.T. L.1000m COFI	Conn. câble 90° H.T. COFI	H.S. Anschluß 90° COFI	H.T. Cable connect. 90° COFI
79	E50328		•	•	Fotoresistenza FC13	Photoresis. FC13	Fotozelle FC13	Ld ph. Unit FC13
82	T20411		•	•	Pompa BFP11 R5 Danfoss	Pompe BFP11 R5 Danfoss	Pumpe BFP11 R5 Danfoss	Pump Danfoss BFP11 R5
83	T20118		•	•	Bobina E.V. Danfoss	Bobine E.V. Danfoss	Spule Danfoss	Solenoid spool Danfoss
84	T20117		•	•	Corpo E.V. Danfoss	Electrovanne Danfoss	Magnetventil Danfoss	Solenoid valve Danfoss

AACO

85	E10514		•	•	Giunto Pl. mot.-pompa K2	Accouplement Pl. K2	PlastikKuplung K2	Coupling K2
----	--------	--	---	---	--------------------------	---------------------	-------------------	-------------

SIMEL

85	E10698		•	•	Giunto Pl. mot.-pompa	Accouplement Pl.	PlastikKuplung	Coupling
86	02AC548		•	•	Filtro gasolio c/preriscaldamento 1/4"	Filtre pre-chauffage 1/4"	Heizölvorwärmfilter 1/4"	Oil pre-heaters filter 1/4"
87	T20241		•	•	Kit OR filtro gasolio	KIT OR filtre gasoil	Kit OR heizölfilter	OR KIToil filter
88	T20242		•	•	Cartuccia filtro	Cartouche filtre	Filterelement	Filter cartridge
89	E20953		•	•	Pressacavo PL. PG11	Embout fixe-cable PG11	Kabelhalter PG11	Cable holder PG11
90	E20954		•	•	Ghiera PL PG11	Embout PG11	Nutmutter PG11	Ring nut PG11
91	E20418		•	•	Protezione pulsante blocco	Protection bouton d'arrêt	Blockierschalterschutz	Stop button protection
92	E50327		•	•	Protezione fotoresistenza	Photoresistance protection	Photozellenschutz	Protection de la photoresistance
96	T20442		•	•	Cavo elettrovalvola	Cable electrovanne	Anschlußkabel für Magnetventil	Solenoid valve cable
97	T20234		•	•	Kit OR filtro gasolio	KIT OR filtre gasoil	Kit OR heizölfilter	OR KIToil filter
98	T20206		•	•	Cartuccia filtro	Cartouche filtre	Filterelement	Filter cartridge
99	T20212		•	•	Bicchiera filtro	Cuve filtre	Filtergehäuse	Filter housing
100	C10513-R		•	•	Borchia Pl. Rossa	Cabochoon	Deckel	Cover
101	E10110N-P		•	•	Commutatore I - II	Interrupteur I - II	Schalter I - II	Switch I - II
102	E20406		•	•	Protezione per commutatore	Protection pour interrupteur	Schalterschutz	Switch plastic profile
104	E10837		•	•	Trasformatore 1300-1500 VA	Transformateur 1300-1500 VA	Zündtrafo 1300-1500 VA	Transformer 1300-1500 VA
105	G06250		•	•	Supporto trasformatore	Support transformateur		Transformer support