

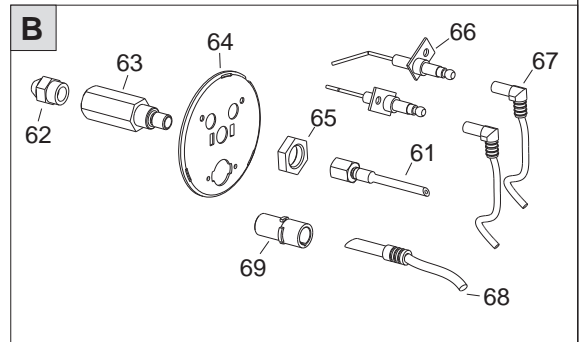

**GE**

**GE 36 - GE 46  
GE 36 DV - GE 46 DV**

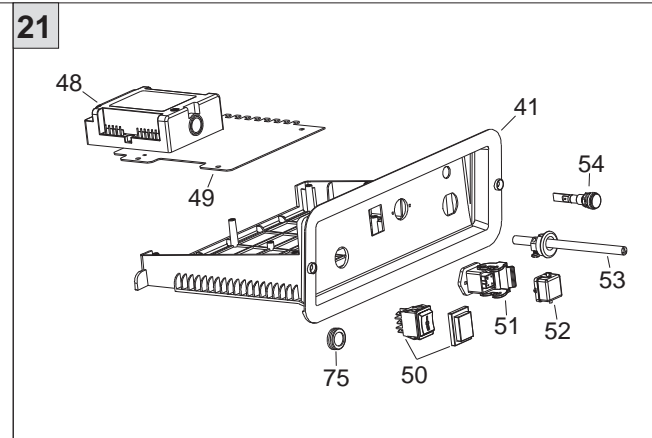
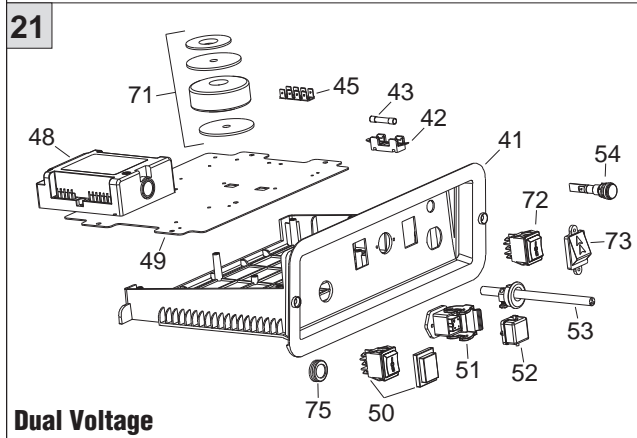
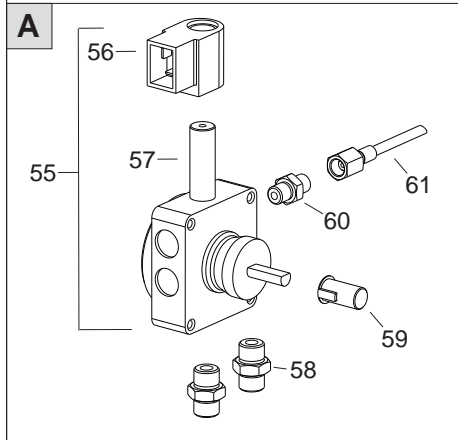
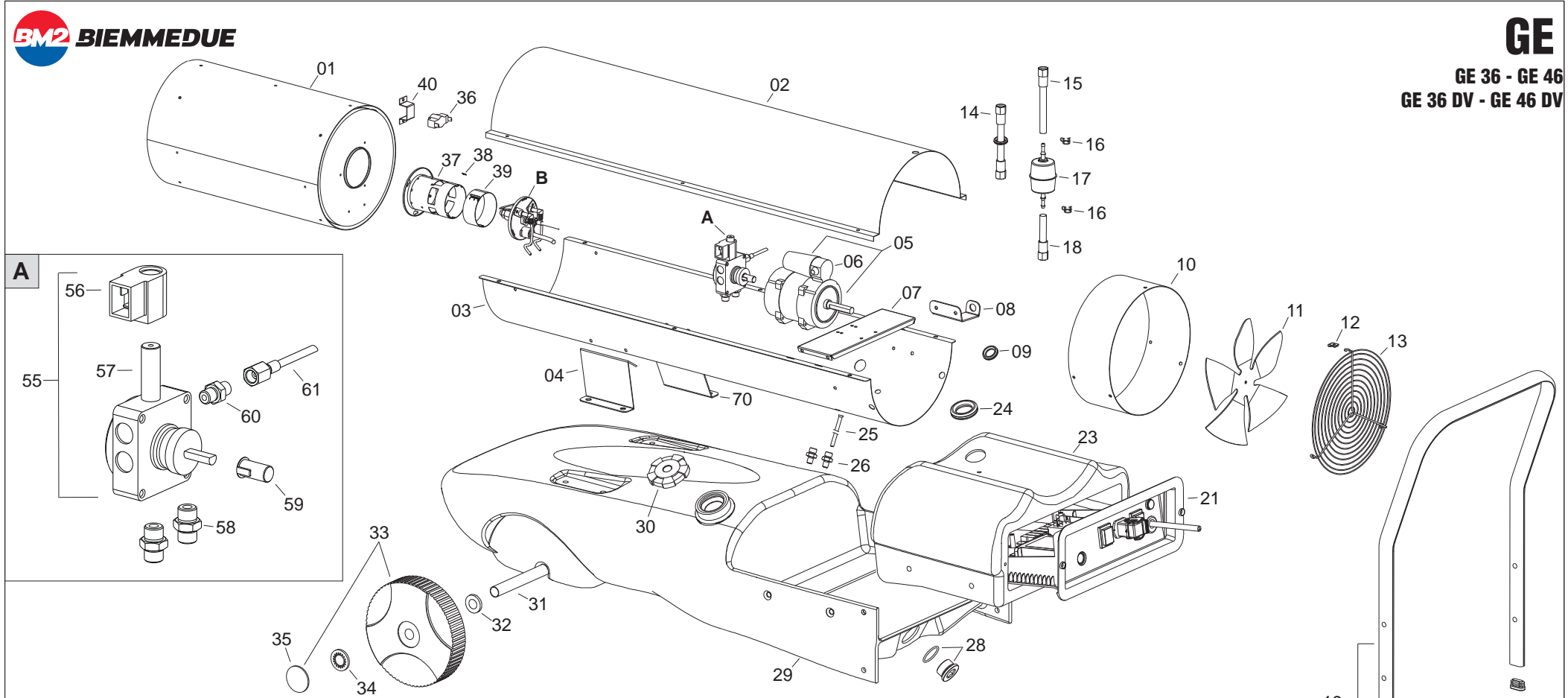

**Dual Voltage**

Da matr. N. - De matr. No. - Von Masch. Nr. - From number:							GE 36	27003801		
							GE 46	27103201		
Pos.	Cod.	€	GE 36	GE 36 DV	GE 46	GE 46 DV	LEGENDA	LEGENDE	NOMENKLATUR	PART LIST
01	G06273 G06274		•	•	•	•	Camera di combustione	Chambre de combustion	Brennkammer	Combustion chamber
02	G06061-3001 G06062-3001		•	•	•	•	Scocca superiore	Carrosserie sup.	Haube	Upper body
03	G06275-3001 G06276-3001		•	•	•	•	Scocca inferiore	Carrosserie Inf.	Karosserie Unterteil	Lower body
04	G06065-9005		•	•	•	•	Staffa supporto carrozzeria SX	Étrier support carrosserie gauche	Haltebügel Verkleidung links	Left chassis support bracket

## AACO

05	E10677 E10687		•	•	•	•	Motore 200W c/condens. Motore 110W c/condens.	Moteur 200W avec condensateur Moteur 110W avec condensateur	Motor 200W mit Kondensator Motor 110W mit Kondensator	Motor 200W with condenser Motor 110W with condenser
06	E11214 E11204		•	•	•	•	Condensatore 6,3 µF Condensatore 4 µF	Condensateur 6,3 µF Condensateur 4 µF	Kondensator 6,3 µF Kondensator 4 µF	Condenser 6,3 µF Condenser 4 µF

## SIMEL

05	E10691 E10692		•	•	•	•	Motore 110W c/condens. Motore 200W c/condens.	Moteur 110W avec condensateur Moteur 200W avec condensateur	Motor 110W mit Kondensator Motor 200W mit Kondensator	Motor 110W with condenser Motor 200W with condenser
06	E11246		•	•	•	•	Condensatore 6,3 µF	Condensateur 6,3 µF	Kondensator 6,3 µF	Condenser 6,3 µF

07	G06272 G06217		•	•	•	•	Supporto motore ventola	Bride support moteur	Motor Flansch	Motor flange
08	G06068-9005		•	•	•	•	Gancio cavo alimentazione	Crochet câble d'alimentation	Haken Netzkabel	Power lead hook
09	C30352		•	•	•	•	Passacavo Ø15	Protection cable Ø15	Kabeltülle Ø15	Cable protection Ø15
10	G06069-3001 G06070-3001		•	•	•	•	Anello protezione ventilatore	Anneau protection ventilateur	Ring Schutzeinrichtung Ventilator	Fan protection ring
11	T10264 T10207		•	•	•	•	Ventola Ø 230 38° Ventola Ø 300 18°	Ventilateur Ø 230 38° Ventilateur Ø 300 18°	Ventilator Ø 230 38° Ventilator Ø 300 18°	Fan Ø 230 38° Fan Ø 300 18°
12	M20402		•	•	•	•	Piastrina doppia U42-032	Plaque elastique U42-032	Klemmutter U42-032	Elastic Plate U42-032
13	P30161 P30165		•	•	•	•	Griglia aspirazione	Grille protection	Schutzgitter	Inlet grille
14	I40328		•	•	•	•	Tubo BP 1/4" F L.300mm	Tube BP 1/4" F L.300mm	Rohr BP 1/4" F L.300mm	Tube BP 1/4" F L.300mm
15	I40327		•	•	•	•	Tubo BP 1/4" F L.185mm	Tube BP 1/4" F L.185mm	Rohr BP 1/4" F L.185mm	Tube BP 1/4" F L.185mm
16	C30729		•	•	•	•	Fascetta per tubo	Collier	Schelle	Clamp
17	I30414		•	•	•	•	Filtro gasolio compl.	Filtre avec cartouche	Filter komp.	Filter with cartridge
18	I40326		•	•	•	•	Tubo BP 1/4" F L.85mm	Tube BP 1/4" F L.85mm	Rohr BP 1/4" F L.85mm	Tube BP 1/4" F L.85mm
19	P20173-9005		•	•	•	•	Maniglia/Piede	Poignée/Support	Handgriff/Stütze	Handle/Support
20	C30361		•	•	•	•	Tappo copritesta	Bouchon	Gummifuss	Plug
21	G00225 G00225-DV		•	•	•	•	Quadro elettrico	Coffret électrique	Elektrokasten	El. componets drawer
23	P50128 P50129		•	•	•	•	Protezione quadro elettrico	Protection tableau électrique	Schutzeinrichtung Schaltschrank	Electrical switchboard protection
24	C30372		•	•	•	•	Passatubo gomma Ø 35	Prot. caoutchouc Ø 35	Kabeltülle Ø 35	Protection cable Ø 35
25	I30696		•	•	•	•	Pescante L.220mm	Pascante L.220mm	Pascante L.220mm	Pascante L.220mm
26	I30737		•	•	•	•	Nipplo OT 1/4" M - M12x1,75 M	Nipplo OT 1/4" M - M12x1,75 M	Nipplo OT 1/4" M - M12x1,75 M	Nipplo OT 1/4" M - M12x1,75 M
28	C30380		•	•	•	•	Tappo Serbatoio M30x1,5	Bouchon de vidange	Abluss Propfen Oel	Drain plug
29	P50130		•	•	•	•	Serbatoio gasolio	Réservoir fuel	Tank	Fuel tank
30	C30356		•	•	•	•	Tappo bocchettone	Bouchon	Pfropfen	Drain plug
31	P20179-9005		•	•	•	•	Assale	Essieu	Achse	Wheel axle
32	M20110		•	•	•	•	Rondella Ø21 x Ø37 x 3	Rondelle Ø21 x Ø37 x 3	Abstandsring Ø21 x Ø37 x 3	Washer Ø21 x Ø37 x 3
33	C10543		•	•	•	•	Ruota Ø 200 - Ø 20	Roue Ø 200 - Ø 20	Rad Ø 200 - Ø 20	Wheel Ø 200 - Ø 20
34	M20203		•	•	•	•	Rondella el. block Ø 20	Clips de fixation Ø 20	Radverschluss Ø 20	Whell holder Ø 20
35	C10513-R		•	•	•	•	Borchia Pl. Rossa	Cabochoon	Deckel	Cover
36	E50109		•	•	•	•	Capsula termostatica Fan	Thermostat bilame Fan	Thermostat Fan	Fan Thermostat
37	G06268		•	•	•	•	Boccaglio	Gueulard	Brennrohr	Blast tube
38	E20671		•	•	•	•	Morsettiera terra	Barrette de connection	Klemmreiche	Terminal board
39	G06260		•	•	•	•	Anello regolazione aria	Volet réglage air	Brennluftklappe	Air regulatoin flap
40	G06221		•	•	•	•	Staffa fissaggio capsula	Box fixing bracket	Kapselbugelbefestigung	Bride de fixage
41	G06153 G06155		•	•	•	•	Supporto quadro elettrico	Support coffret électrique	Steuergeräthalerung	Electr. componets drawer
42	E20508		•	•	•	•	Porta fusibile	Porte fusible	Sicherungschalter	Fuse holder
43	E10307		•	•	•	•	Fusibile vetro (6x30) 6,3A	Fusible (6x30) 6,3A	Sicherung (6x30) 6,3A	Fuse (6x30) 6,3A
45	E20319		•	•	•	•	Morsettiera terra	Barrette de connection	Klemmreiche	Terminal board
48	E40122		•	•	•	•	Apparecchiatura BRAHMA TGRD 71	Coffret BRAHMA TGRD 71	Steuergerät BRAHMA TGRD 71	Control box BRAHMA TGRD 71

Da matr. N. - De matr. No. - Von Masch. Nr. - From number:						GE 36	27003801			
						GE 46	27103201			
Pos.	Cod.	€	GE 36	GE 36 DV	GE 46	GE 46 DV	LEGENDA	LEGENDE	NOMENKLATUR	PART LIST
49	G06184 G06073		•	•	•	•	Piastra supporto elementi elettrici	Plaqu support	Tragplatte für elektrische Teile	Plate for electrical components
50	E10102-P		•	•	•	•	Interruttore bipolare 0 - 1	Interrupteur 0 - 1	Schalter 0 - 1	Switch 0 - 1
51	E20640		•	•	•	•	Connettore presa 3P+T	Fiche thermostat 3P+T	Thermostat stecker 3P+T	Thermostat plug 3P+T
52	E20665		•	•	•	•	Tappo	Bouchon	Pfropfen	Drain plug
53	E30448 E30445		•	•	•	•	Cavo elettrico c/spina e morsettieria	Câble avec fiche et presse câble	Kabel mit steckdose und kabel Führung	El. wire with plug and cable fastener
54	E11030		•	•	•	•	Lampada 230V	Lampe 230V	Kontrolllampe 230V	Lamp 230V
55	T20429		•	•	•	•	Pompa Danfoss BFP01	Pompe Danfoss BFP01	Pumpe Danfoss BFP01	Pump Danfoss BFP01
56	T20114		•	•	•	•	Bobina E.V. BFP Danfoss	Bobine E.V. BFP Danfoss	Spule BFP Danfoss	Solenoid spool BFP Danfoss
57	T20117		•	•	•	•	Corpo E.V. Danfoss	Electrovanne Danfoss	Magnetventil Danfoss	Solenoid valve Danfoss
58	I20104		•	•	•	•	Nipplo FE 1/4" MM	Nipplo FE 1/4" MM	Nipplo FE 1/4" MM	Nipplo FE 1/4" MM
<b>AACO</b>										
61	E10513		•	•	•	•	Giunto Pl. mot.-pompa K1	Accouplement Pl. K1	PlastikKuplung K1	Coupling K1
<b>SIMEL</b>										
59	E10698		•	•	•	•	Giunto Pl. mot.-pompa	Accouplement Pl.	PlastikKuplung	Coupling
60	I20115		•	•	•	•	Nipplo FE 1/8" MM	Nipplo FE 1/8" MM	Nipplo FE 1/8" MM	Nipplo FE 1/8" MM
61	I40192		•	•	•	•	Microtubo	Microtube	Microschlauch	Micropipe
62	T20339		•	•	•	•	Ugello 0,60 GPH 80°S	Gicleur 0,60 GPH 80°S	Düse 0,6 0 GPH 80°S	Nozzle 0,60 GPH 80°S
	T20315		•	•	•	•	Ugello 0,85 GPH 80°S	Gicleur 0,85 GPH 80°S	Düse 0,8 5 GPH 80°S	Nozzle 0,85 GPH 80°S
63	I33001		•	•	•	•	Canotto portaugello	Support gicleur	Düsehalter	Nozzle support
64	G06267		•	•	•	•	Flangia supp. Bruciatore Ø 80mm	Bride Brûleur Ø 80mm	Brenner Flansch Ø 80mm	Burner flange Ø 80mm
65	I31034		•	•	•	•	Controdado OT. M14	Ecrou M14	Mutter M14	Nut M14
66	E10248		•	•	•	•	Elettrodo c/piastrina	Électrode	Elektrode	Electrode
67	G02078		•	•	•	•	Cavo A.T. L.1000m	Conn. câble 90°H.T.	H.S. Anschluß 90°	H.T. Cable connect. 90°
68	E50328		•	•	•	•	Fotoresistenza BRAHMA FC 13	Photoresis. BRAHMA FC 13	Fotozelle BRAHMA FC 13	Ld ph. Unit BRAHMA FC 13
69	E50327		•	•	•	•	Protezione fotoresistenza	Photoresistance protection	Photozellenschutz	Protection de la photoresistence
70	G06088-9005		•	•	•	•	Staffa supporto carrozzeria DX	Étrier support carrosserie droit	Haltebügel Verkleidung rechts	Right chassis support bracket
71	E10836		•	•	•	•	Trasformatore 400 VA	Transformateur 400 VA	Zündtrafo 400 VA	Transformer 400 VA
72	E10110N-P		•	•	•	•	Commutatore I - II	Interrupteur I - II	Schalter I - II	Switch I - II
73	E20406		•	•	•	•	Protezione per commutatore	Protection pour interrupteur	Schalterschutz	Switch plastic profile
75	E20418		•	•	•	•	Protezione pulsante blocco	Protection bouton d'arrêt	Blockierschalterschutz	Stop button protection